

Hilti FS-ONE MAX High Performance Intumescent Firestop Sealant

Product Info. & Method Statement	2 - 6
Test Report	
- University of Macau No. 2006-FRT20	7 - 29
- Assessment report No. 2015-A15	30 - 37
Approvals	
- Macau Fire Services	38
- FM (Factory Mutual)	39
- UL (Underwriters Lab. Inc.)	40
Country of Origin	41
LEED Letter	42
Material Safety Data Sheet	43 - 47
Job Reference	48 - 50

Make your submission simple!

To download the most updated submission folders and technical manuals, visit <http://www.hilti.com.hk/download>



Recycling one ton of paper saves 17 trees and 7000 gallons of water. Please consider your environmental responsibility before using the hard copy version!

High performance intumescent firestop sealant FS-ONE MAX

Product description

- Intumescent (expands when exposed to fire) firestop sealant that helps protect combustible and non-combustible penetrations for up to 4 hours fire rating

Applications

- Effectively seals most common through penetrations in a variety of base materials
- For use on concrete, masonry and drywall
- Mixed and multiple penetrations
- Metal pipe penetrations
- Insulated metal pipe penetrations
- Plastic pipe penetrations
- Cable bundles and trays
- HVAC penetrations

Advantages

- One product for a variety of common through penetrations
- Cost-effective and easy-to-use solution
- Water-based and paintable
- W-rated systems available
- Ethylene glycol-free
- Industry leading VOC results
- Convenient multi application firestop solution for penetrations

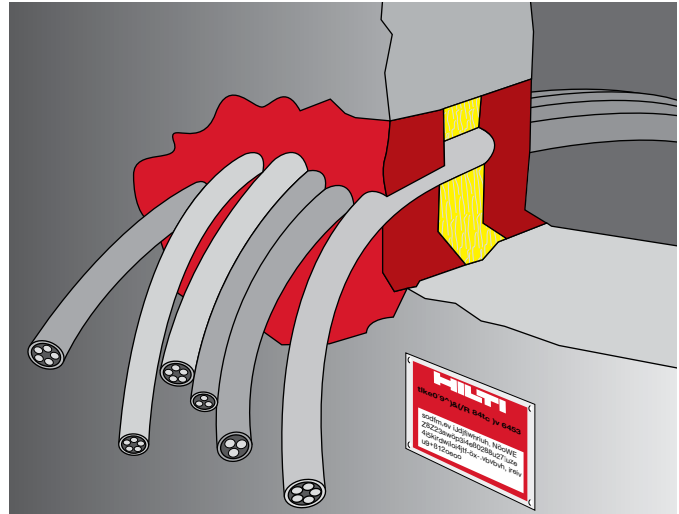

Technical Data*	
Chemical basis	Water-based acrylic dispersion
Color	Red
Application temperature	41°F to 104°F
Storage and transportation range	41°F to 77°F
Approx. cure time *	4 mm / 3 days
Shelf life	12 months **
Temperature resistance range	-4°F to 212°F
Mold and mildew performance	Class 0 (ASTM G21-13)
Mold and mildew resistant	Yes
Surface burning characteristics (ASTM E 84-14)	Flame Spread: 0 Smoke Development: 10
Approvals	California State Fire Marshal - in progress
Tested in accordance with	ASTM G21 ASTM E 90 CAN/ULC-S115 UL 1479 ASTM E 814 ASTM E84

* At 75°F (24°C) and 50% relative humidity
** from date of manufacture

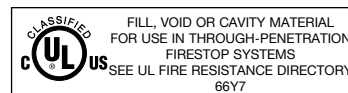

Subject: Method Statement of FS-ONE MAX for Penetration Seal.
Material: FS-ONE T ØY firestop sealant
Accessory: Hilti Dispenser CFS-DISP or Hilti Dispenser CS 270-P1 or equivalent.

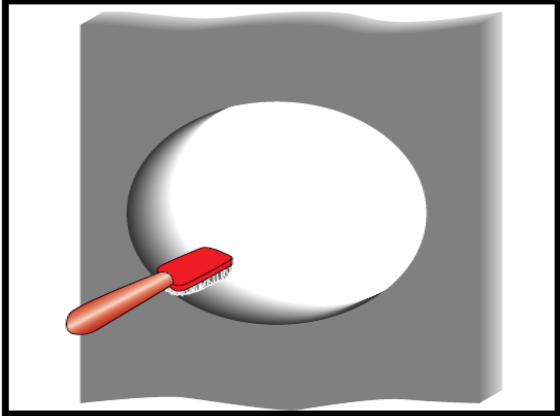
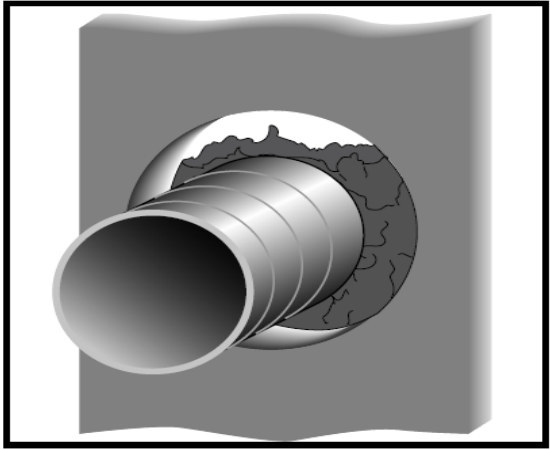
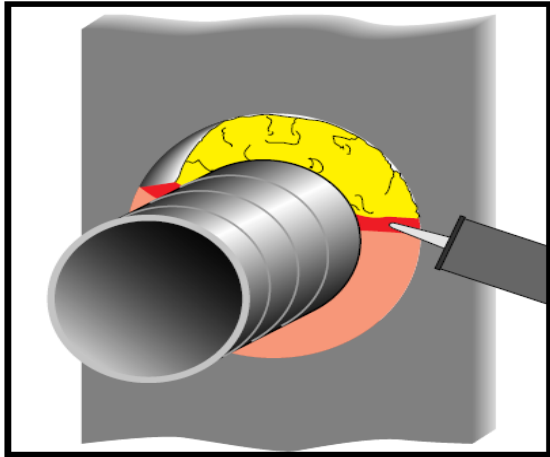
Setting Operation		
1	<p>Clean the opening. Surfaces to which FS-ONE T ØY will be applied should be cleaned of loose debris, dirt, oil, wax and grease. The surface should be moisture and frost free.</p>	
2	<p>Insert the required fill of mineral wool and backer.</p>	
3	<p>Apply firestop FS-ONE T ØY over backer.</p>	

<p>4</p>	<p>Smooth the firestop sealant with a trowel before the skin forms. Once cured, FS-ONE TCE can only be removed mechanically.</p>	<p>A 3D perspective illustration of a grey metal pipe protruding from a grey wall. An orange firestop sealant is applied around the pipe. A silver trowel is shown smoothing the sealant on the wall surface.</p>
<p>5</p>	<p>For maintenance reasons, a penetration seal could be permanently marked with an identification plate. In such a case, mark the Identification plate and fasten it in a visible position next to the seal.</p>	<p>A 3D perspective illustration of a grey metal pipe protruding from a grey wall. An orange firestop sealant is applied around the pipe. A small red identification plate with the HILTI logo and 'Firestop Systems' text is fastened to the wall next to the sealant.</p>

Safety precautions:

- Never use in areas immersed in water
- Keep out of reach of children
- Read the Material Safety Data Sheet
- Eyes and hands must be suitably protected
- Avoid contact with eyes/skin
- Only use in well ventilated areas

Subject: Method Statement of FS-ONE MAX for Linear Joint Seal
Material: FS-ONE T ØY firestop sealant
Accessory: Hilti Dispenser CFS-DISP or Hilti Dispenser CS 270-P1 or equivalent.

Setting Operation		
1	<p>Clean the opening. Surfaces to which FS-ONE T ØY will be applied should be cleaned of loose debris, dirt, oil, wax and grease. The surface should be moisture and frost free.</p>	<p>A diagram showing a brush being used to clean a joint opening. The brush is positioned at the corner of a joint, and a double-headed arrow indicates the cleaning motion.</p>
2	<p>Insert fill of mineral wool or backing material (if required)</p>	<p>A diagram showing a yellow rectangular backing material being inserted into a joint opening. A downward arrow indicates the direction of insertion.</p>
3	<p>Apply FS-ONE T ØY over the backing material .</p>	<p>A diagram showing a Hilti dispenser applying red FS-ONE T ØY sealant into a joint opening. The sealant is being applied over the yellow backing material.</p>

<p>4</p>	<p>Smooth FS-ONE T BY Using a trowel before the skin forms. Can only be removed mechanically once it is cured.</p>	
<p>5</p>	<p>For maintenance reasons, a penetration seal would be permanently marked with an identification plate. In such a case mark the identification plate and fasten it in a visible position next to the seal</p>	

Safety precautions:

- Never use in areas immersed in water
- Keep out of reach of children
- Read the Material Safety Data Sheet
- Eyes and hands must be suitably protected
- Avoid contact with eyes/skin
- Only use in well ventilated areas



檢驗報告

No. 2006-FRT20

產品名稱: FS-ONE Firestop Sealant

報告發致下列單位:

送檢單位: 喜利得(香港)有限公司
製造商: Hilti

報告日期: 2006年5月30日

澳門大學



檢驗報告

No: 2006-FRT20

產品名稱	FS-ONE Firestop Sealant
送檢單位名稱	喜利得(香港)有限公司
產品銷售代理	喜利得(香港)有限公司
製造商	Hilti
試件產地	德國
樣本技術數據	密度: 約 $1.5g/cm^3$ 顏色: 紅色 施工溫度: $+5^{\circ}C$ 至 $+40^{\circ}C$ 施工時間: 20-30 分鐘 固化速度: 4mm/3 日 容許變形: 5%
送檢日期	2006 年 4 月 28 日
送檢時附上報告	Warrington Fire Research Centre Ltd. 報告號碼: WARRES NO.62293/A
檢驗項目	耐火性能
檢驗依據	BS476:Part 20
檢驗日期	2006 年 5 月 9 日
檢驗結論	經檢驗, 此膨脹性防火泥膠的隔熱性達到 46 分鐘, 而完整性則能達到 240 分鐘。

檢測人員,

審核,

黃傑勇
澳門大學實驗員

譚立武
澳門大學機電工程系主任

1 檢測目的

- 1.1 根據英國標準 BS476 第 20 部份:1987，測試 FS-ONE 膨脹性防火泥膠之耐火性。

2 引言

- 2.1 根據送檢單位的要求，膨脹性防火泥膠之耐火測試需滿足英國標準 BS476 第 20 部份:1987 之要求。
- 2.2 試件由製造商於 2006 年 4 月 28 日安裝，並於 2006 年 5 月 9 日進行測試。

3 試件構造

- 3.1 試件由輕質混凝土及膨脹性防火泥膠組成。主要測試試件尺寸為 600mm x 600mm x 150mm，2 束分別為包含 5 條直徑為 11mm 的小電纜及直徑為 50mm 的 PVC 喉將各穿過該膨脹性防火泥膠，而電纜及 PVC 喉的總長度為 550 mm。試件以輕質混凝土安裝於檢測框內，詳細圖則及試件構造可參照附錄 A。
- 3.2 本報告所繪製之圖則及其材料是根據製造商所提供的資料而作。試件之厚度及結構由本中心之檢測員驗證。
- 3.3 試件由送檢單位安裝於檢測框上進行測試，該檢測框由檢驗單位提供。
- 3.4 試件在測試前數天內安裝。



4 測試設備及程序

- 4.1 測試設備按照英國標準 BS476 第 20 部份:1987 的要求設置。
- 4.2 爐體內部之平均溫度值由 5 個平均分佈於爐內的熱電偶取得，根據英國標準 BS476：第 20 部分：1987 所指定之溫度時間關係而操控升溫。溫度時間記錄圖見附錄 B。
- 4.3 爐體內設有壓力計以監察爐體壓力。小型檢測爐的壓力變化並不明顯。
- 4.4 試件的背火面均設有熱電偶，以作監察溫度之用，熱電偶分佈位置見附錄 A 之圖 3 及圖 4。背火面所有熱電偶均用作判斷試件的絕熱性。
- 4.5 測試過程中，棉墊及縫隙測量探棒用作評估試件的完整性。
- 4.6 測試過程中，應記錄試件的變形情況和試件出現全部或部分毀壞時的時間。試件背火面如有火焰並持續 10 秒或以上，以及有煙散發出的情況也應記錄。
- 4.7 背火面及向火面於測試前後需拍照記錄。測試過程中，需拍照及用攝錄機記錄背火面情況以作日後評估之用。

5 測試數據及資料

- 5.1 測試過程所記錄之數據可參考附錄 B，記錄內容如下：
 - 5.1.1 實際爐溫按照英國標準 BSI 所指定溫度時間關係圖。
 - 5.1.2 由熱電偶所記錄背火面的溫度。
- 5.2 在測試過程中，試件的實驗狀況已詳細記錄於附錄 C 中以供參考。

- 5.3 有關試件圖片, 見附錄 D。
- 5.4 測試開始時周圍環境溫度為 30°C。
- 5.5 在送檢單位的同意下, 試件在 240 分鐘終止整個測試。

6 耐火極限之評定條件

6.1 按英國標準 BS476 第 20 部份:1987 之標準, 試件之耐火表現將會根據以下之條件作評定:

6.1.1 完整性 - 當測試過程中, i) 在試件之背火面進行棉墊點燃測試; ii) 如背火面出現較大的裂縫, 用 6mm 及 25mm 直徑之量測棒來量測裂縫之寬和深度。如棉墊沒有被背火面之高溫點燃及試件背火面未出現能讓量測棒插入貫通之裂縫, 試件之完整性才被判斷為合格。

6.1.2 絕熱性 - 背火面最高平均溫度及單點溫度與超始溫度之升幅不得超過 140°C 和 180°C。

7 結論

7.1 根據 BS476 英國標準第 20 部分所制定的準則 — 完整性和絕熱性評估試樣的耐火性能測試結果如下:

完整性	不少於 240 分鐘
絕熱性	46 分鐘

8 限制說明

- 8.1 本測試結果僅反映特定測試條件下, 建築構件之試驗情況。此測試結果並非判斷試件在實際應用時防火特性的唯一標準, 同時亦不反映試樣在實際火場上所能表現的防火性能。
- 8.2 本試驗結果只反映與報告相同之物料、結構、厚度及安裝方法之系統, 如將此試驗結果應用於試件組合型式不同的情況時, 應按照實際用途而作出相應之評估。



附錄 A
試件構造說明及附圖



圖 1 試件之正視圖



圖 2 試件之截面圖

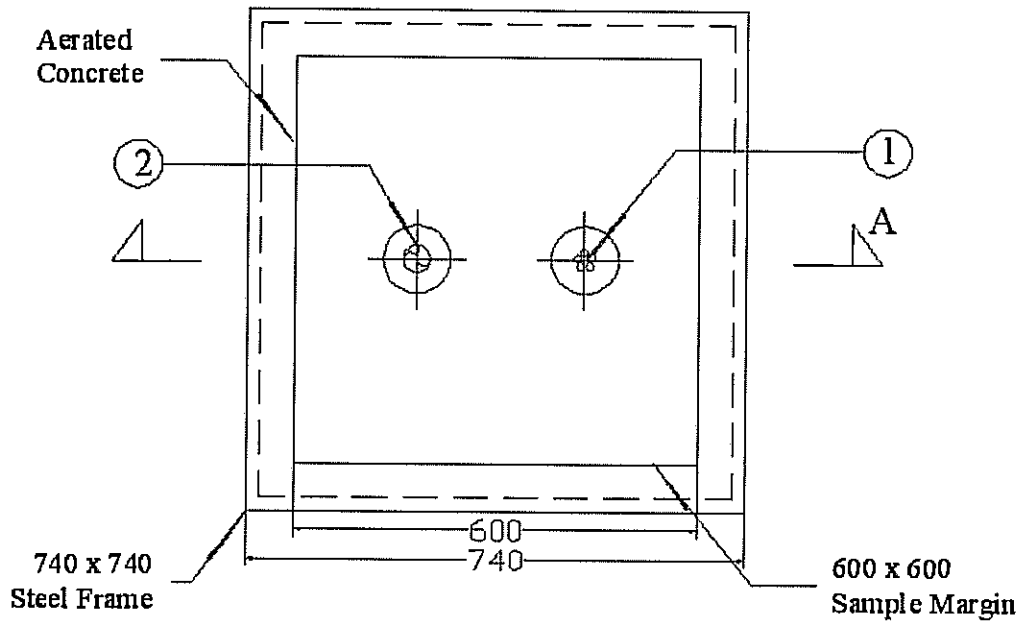

圖 3 熱電偶分佈位置圖 (一)

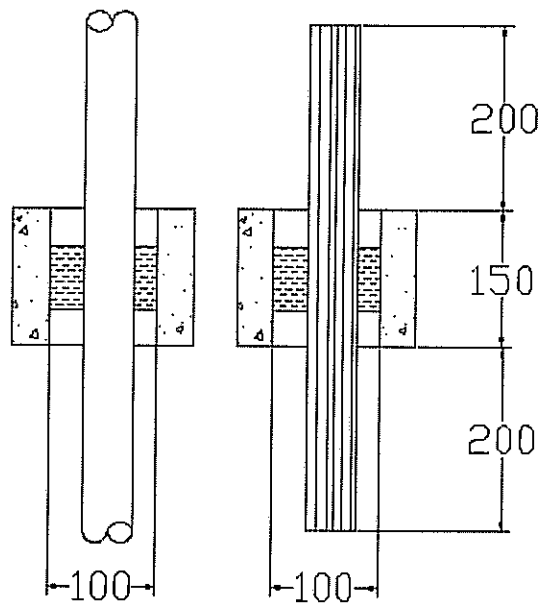

圖 4 熱電偶分佈位置圖 (二)

試件資料

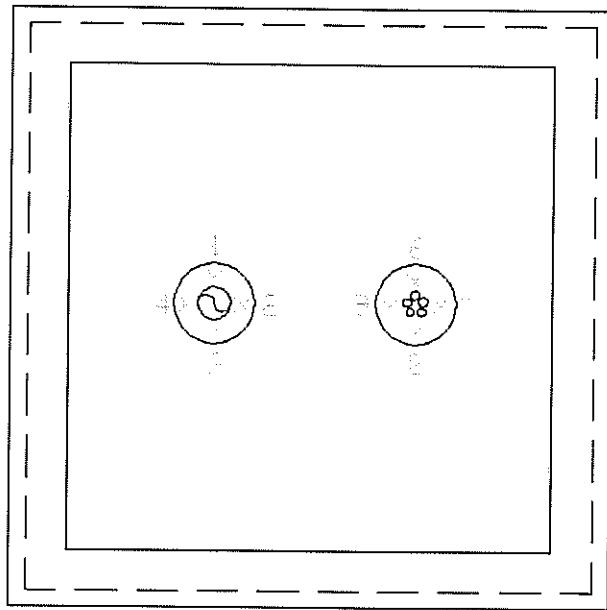
(參照圖 1 至圖 4)

(除非特別指定, 否則全部數值都為標準值)

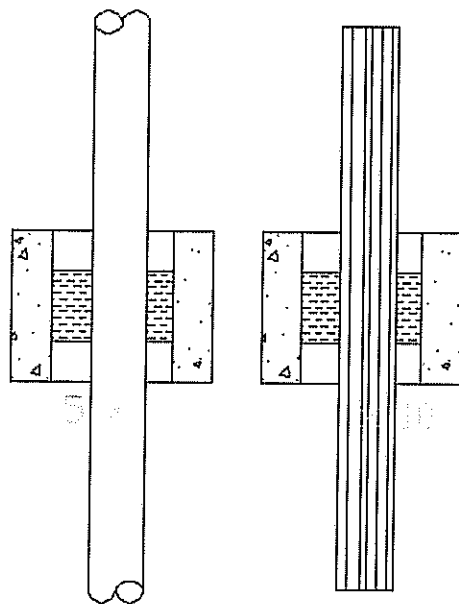
(全部資料和數值由喜利得(香港)有限公司提供)

表 1 材料列表

Item		Description	
1.	Specimen	(i) Product	FS-One
		(ii) Cable Bundle	5 nos armoured cables
		(iii) Cable	Overall 11mm dia. Of plastic cable bundle
		(iv) Opening size	4 hole with mineral wool density 60kg/m3
		(v) Mastic	2 depth FS-One both sides
2.	Specimen	(i) Product	FS-One
		(ii) Cable Bundle	2 dia PVC pipe
		(iii) Opening size	4 hole with mineral wool density 60kg/m3
		(iv) Mastic	2 depth FS-One both sides

附錄 B
測試數據



圖 5 平均爐溫與標準(溫度/時間)曲線圖



圖 6 背火面平均溫度/時間曲線圖

表 2 平均爐溫與標準溫度之比較

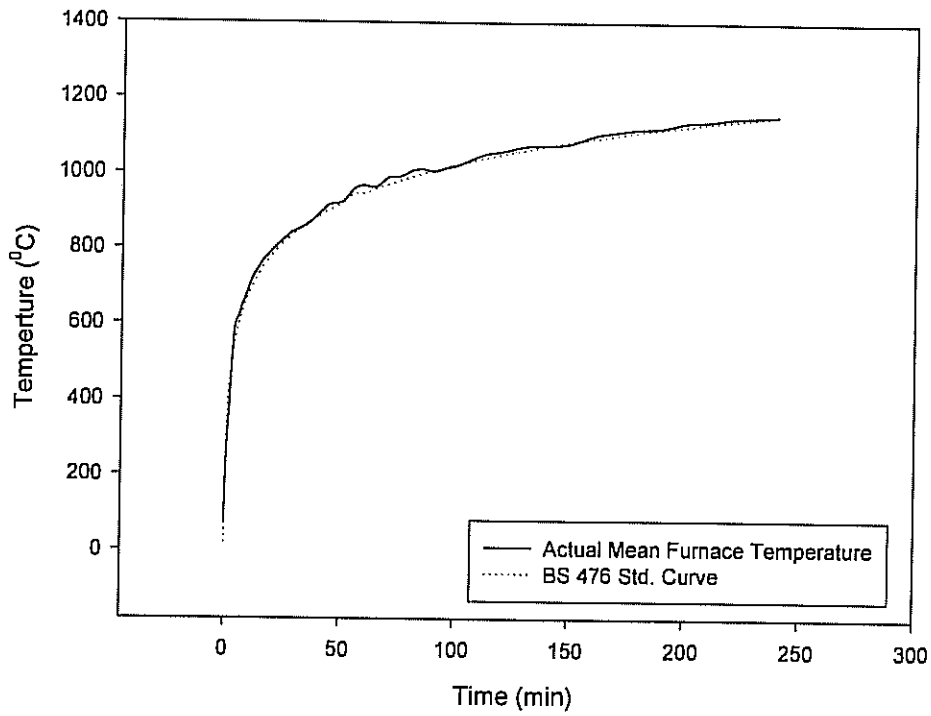
Time (minute)	Standard Furnace Temperature (°C)	Actual Furnace Temperature (°C)	BS476 Tolerance (%)	Percentage Difference (%)
0	20.00	68.63		
1	349.21	275.21		
2	444.50	381.64		
3	502.29	501.21		
4	543.89	582.86		
5	576.41	607.93		
6	603.12	621.44		
7	625.78	645.18		
8	645.46	660.82		
9	662.85	677.52		
10	678.43	696.74	±15	5.26
12	705.44	726.36		
14	728.31	746.00		
16	748.15	767.57		
18	765.67	780.58		
20	781.35	794.85		
22	795.55	806.64		
24	808.52	818.40		
26	820.45	829.28		
28	831.50	839.99		
30	841.80	846.48	±10	2.70
35	864.80	863.18		
40	884.74	890.81		
45	902.34	916.08		
50	918.08	921.70		
55	942.83	955.85		
60	945.34	966.06		
70	968.39	987.17		
80	988.37	1004.83		
90	1005.99	1004.55		
100	1014.08	1013.41		
110	1036.02	1044.63		
120	1049.04	1057.21		
130	1061.02	1070.99		
140	1072.11	1073.94		
150	1082.44	1079.65		
160	1092.10	1099.77		
170	1101.18	1109.83		
180	1109.74	1118.01		
190	1117.84	1121.94		
200	1125.52	1135.14		
210	1132.82	1139.11		
220	1139.79	1147.44		
230	1146.44	1150.85		
240	1152.82	1154.24	±5	3.65

表 3 背火面單點及平均溫度 (°C)

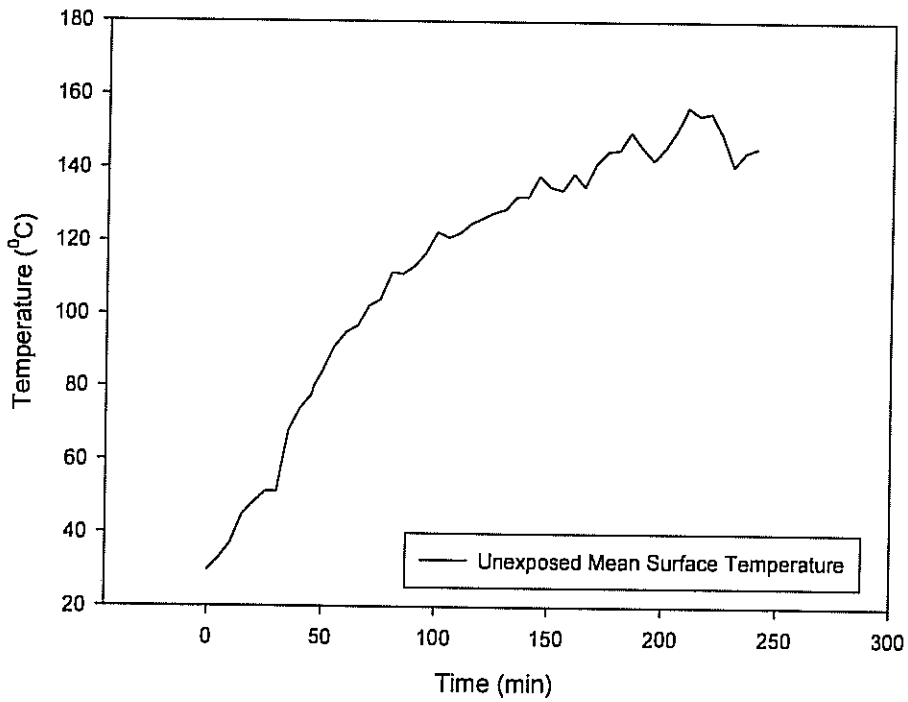
Time (minute)	Thermocouple Number				
	1	2	3	4	5
0	29.95	29.79	29.66	29.77	30.68
5	29.95	30.11	29.82	29.91	33.15
10	30.37	30.46	30.13	30.22	38.62
15	31.73	32.73	31.46	31.42	69.93
20	34.55	37.80	37.02	34.71	80.19
25	36.82	40.84	39.86	36.80	79.80
30	38.71	43.25	41.68	39.26	73.47
35	40.22	44.07	42.10	41.65	66.57
40	43.62	46.68	44.22	47.30	70.87
45	47.94	49.73	45.92	53.94	71.37
46	49.24	50.74	47.05	55.89	71.24
50	53.85	55.06	50.35	61.05	75.32
55	59.18	60.67	54.51	66.66	74.82
60	62.56	65.63	57.87	69.93	72.66
65	65.21	69.49	60.04	71.59	71.48
70	68.53	73.10	62.36	74.03	73.42
75	69.45	75.85	64.45	75.74	68.09
80	72.35	81.26	65.76	77.51	66.44
85	71.48	82.88	64.93	77.11	61.27
90	71.59	84.20	64.73	77.09	58.42
95	72.48	87.81	65.63	77.68	59.64
100	73.71	90.17	66.64	78.38	60.89
105	72.88	92.08	66.29	77.68	57.67
110	72.27	90.98	64.86	76.37	57.56
115	72.81	91.75	65.50	76.57	57.76
120	70.85	89.21	63.46	74.78	55.89
125	72.03	91.95	64.36	74.65	56.53
130	70.74	90.70	62.93	73.01	56.51
135	71.87	90.57	64.80	74.49	61.33
140	71.35	91.03	63.81	73.44	63.20
145	73.03	90.63	65.54	74.75	68.44
150	73.01	88.68	65.57	74.80	68.92
155	72.62	87.72	64.64	74.10	68.96
160	72.81	87.72	65.17	74.30	70.74
165	71.61	86.73	63.55	72.72	70.19
170	74.56	86.19	66.73	75.61	77.16
175	74.71	85.18	67.43	75.78	76.98
180	74.67	83.89	67.08	75.63	75.26
185	76.96	85.86	69.62	77.75	78.62
190	76.46	83.67	68.70	77.57	79.54
195	74.08	80.72	67.23	76.02	75.63
200	76.11	82.07	69.27	77.53	80.52
205	76.87	83.01	71.57	78.86	80.54
210	78.62	83.45	73.58	80.52	82.60
220	80.30	84.22	74.89	81.79	85.51
230	77.09	81.40	71.76	78.64	81.53
240	77.44	82.91	72.37	78.68	83.65

表3 背火面單點及平均溫度 (°C)

Time (minute)	Thermocouple Number					Average Temperature (°C)
	6	7	8	9	10	
0	30.33	30.64	27.61	28.11	30.77	29.73
5	32.20	31.44	27.55	28.22	57.91	33.03
10	35.35	34.73	30.33	32.17	78.38	37.08
15	40.06	38.77	34.48	37.24	100.85	44.87
20	47.05	46.88	54.40	54.47	54.58	48.17
25	51.82	50.65	58.09	58.17	58.15	51.10
30	57.03	57.50	53.39	53.26	53.35	51.09
35	61.38	62.50	62.78	70.72	187.31	67.93
40	68.81	68.42	68.72	79.84	199.61	73.81
45	73.88	73.14	71.41	82.84	206.63	77.68
46	75.19	75.85	74.86	84.96	213.28	79.83
50	80.74	80.04	78.86	89.19	220.47	84.49
55	87.72	85.47	86.71	93.57	240.42	90.97
60	91.95	90.21	92.93	97.25	248.76	94.98
65	93.68	93.13	100.37	100.66	242.63	96.83
70	103.78	96.84	105.37	107.18	257.35	102.20
75	101.76	100.44	111.47	114.32	259.71	104.13
80	117.32	104.05	119.47	124.32	284.86	111.33
85	116.71	106.12	121.95	131.63	275.58	110.97
90	119.82	110.35	124.92	136.84	283.39	113.14
95	126.99	113.62	124.58	144.17	295.24	116.78
100	137.58	118.14	132.48	153.71	313.71	122.54
105	134.22	123.83	*	157.89	306.74	121.03
110	136.24	123.76	*	167.80	311.48	122.37
115	144.89	131.99	*	171.57	311.76	124.96
120	141.03	133.98		177.94	330.17	126.37
125	146.13	137.74		178.51	329.04	127.88
130	137.96	139.19		183.64	344.04	128.75
135	149.68	146.74		187.99	342.47	132.22
140	145.07	147.79		184.55	349.76	132.22
145	157.91	155.61		197.64	357.86	137.93
150	158.21	159.04		195.87	330.60	134.97
155	154.16	157.26		192.13	334.47	134.01
160	154.41	158.61		204.27	358.94	138.55
165	143.05	156.99		198.29	351.74	134.99
170	167.61	167.55		202.75	353.95	141.35
175	165.05	171.75		210.76	374.66	144.70
180	165.35	173.48		210.29	380.21	145.10
185	177.74	184.12		218.03	380.90	149.96
190	170.84	183.30		213.80	358.55	145.83
195	155.20	189.27		211.01	360.84	142.22
200	166.98	191.23		216.38	357.40	145.78
205	169.84	192.31		232.00	369.32	150.48
210	183.18	197.23		240.24	390.47	156.65
220	184.35	201.59		225.68	378.63	155.22
230	163.26	193.65		202.63	317.35	140.81
240	167.46	197.09		213.39	337.76	145.64

*: drop-off of the temperature sensor

附錄 C
觀察情況

表 4 測試過程中，觀察試件情況如下

時間 (小時:分鐘)	事件
-0:01	攝錄機、監察和操控儀器啓動。
0:00	開啓石油氣閥，測試開始。周圍環境溫度爲 30°C。
0:04	背火面電線附近有白煙溢出。
0:06	於 0:04 提及之冒煙情況減弱。
0:25	於 0:06 提及之冒煙情況仍然持續。
0:30	背火面電線外皮熔掉。
0:46	熱電偶(10 號)溫度記錄爲 213°C。絕熱性失效。
0:50	背火面電線間防火填塞 FS-ONE Firestop Sealant 逐漸膨脹。
1:00	試件之完整性仍能達到標準。
1:10	背火面電線附近冒煙仍然持續。
1:30	背火面 PVC 管附近有少量白煙溢出。
1:45	背火面 PVC 管附近的防火填塞 FS-ONE Firestop Sealant 逐漸膨脹。
1:50	於 1:30 提及之冒煙情況停止。
2:00	試件之完整性仍能達到標準。
2:30	背火面電線附近冒煙仍然持續。
2:45	背火面電線間的防火填塞 FS-ONE Firestop Sealant 繼續膨脹。
3:00	試件之完整性仍能達到標準。
3:30	背火面電線附近冒煙仍然持續。
4:00	試件之完整性仍能達到標準。 在送檢單位同意情況下，測試結束。
<i>備註</i>	<i>背火面結構仍完整(見圖 20)</i>

附錄 D
圖片



圖 7 測試前試件向火面



圖 8 測試前試件向火面過牆大樣圖(一)

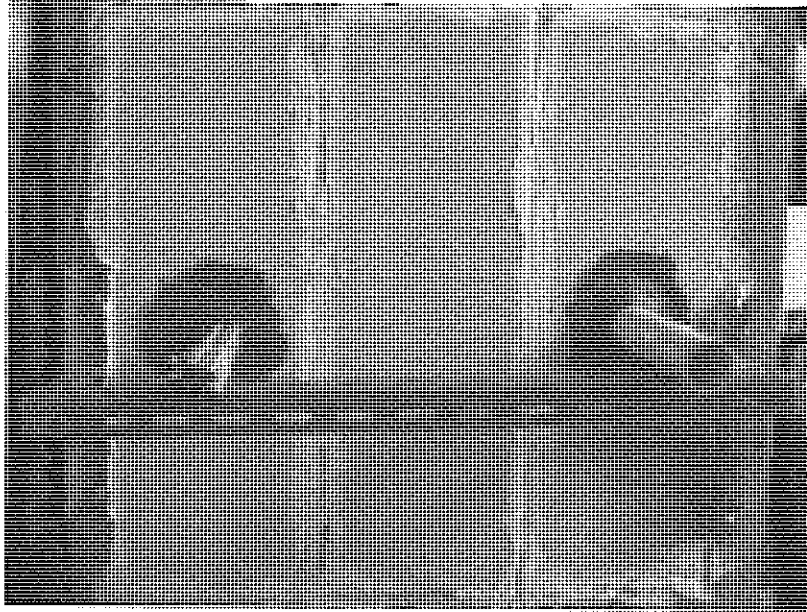

圖 9 測試前試件向火面過牆大樣圖(二)

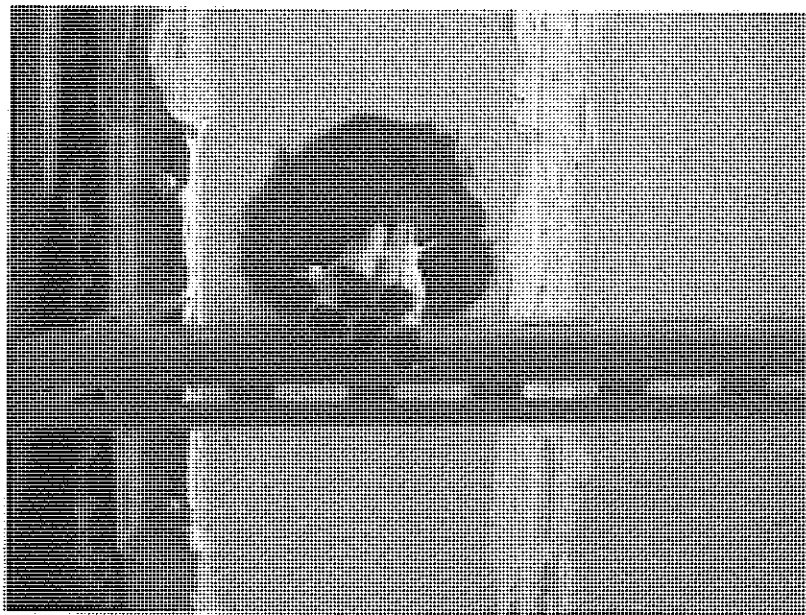

圖 10 熱電偶位置分佈圖(一)

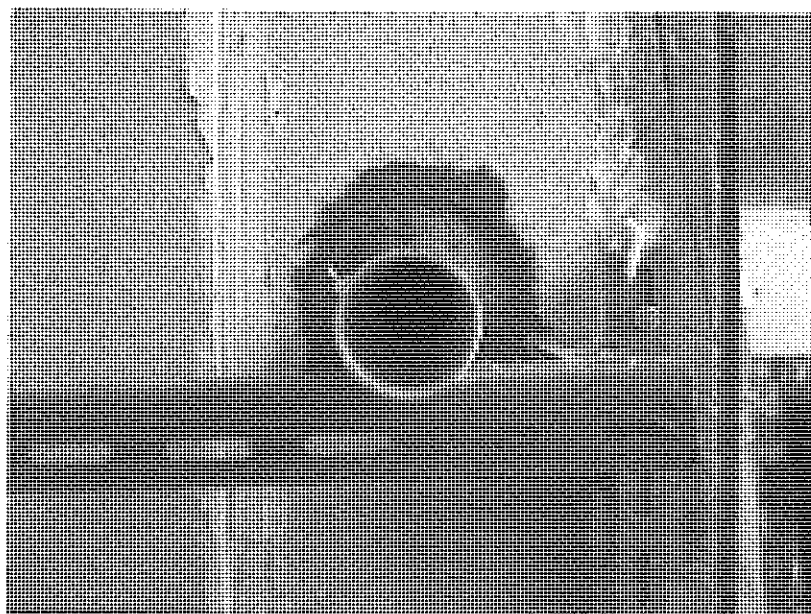

圖 11 熱電偶位置分佈圖(二)

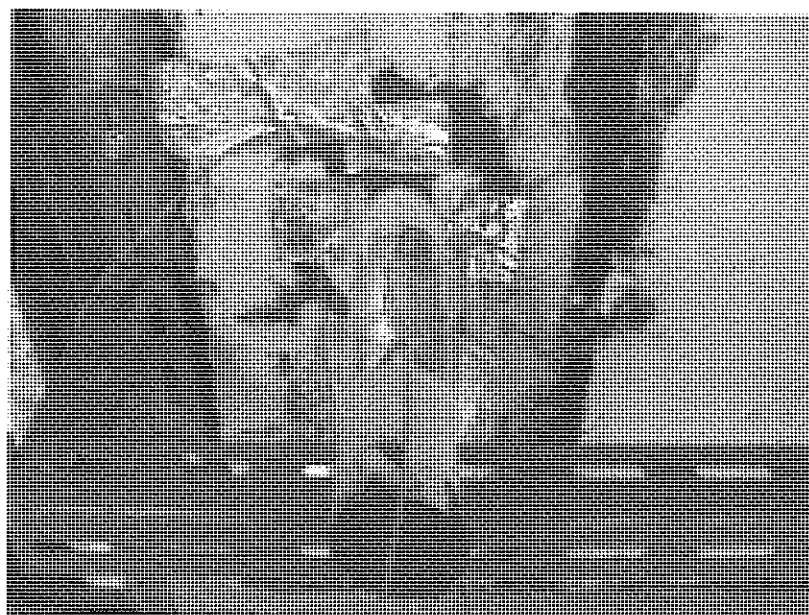

圖 12 測試前試件背火面



圖 13 測試 30min 時試件背火面

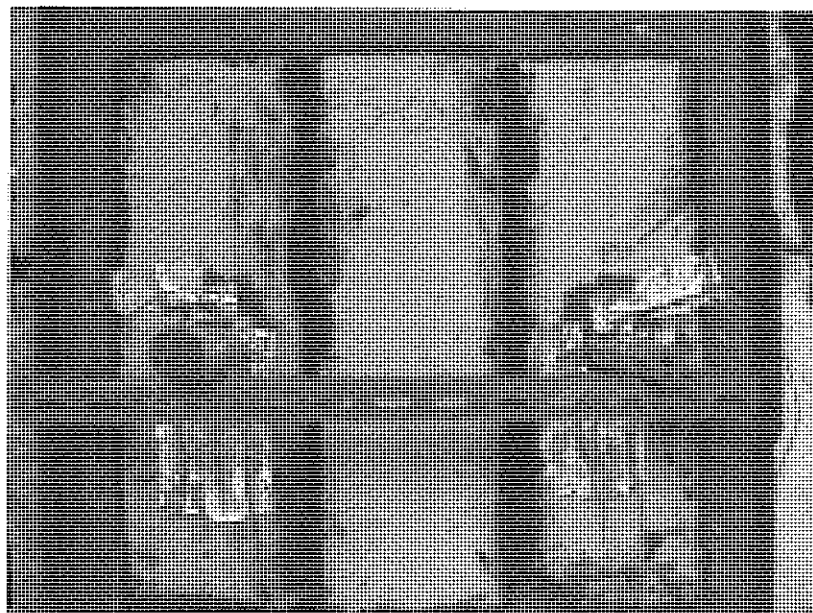

圖 14 試件之冒煙情況(一)

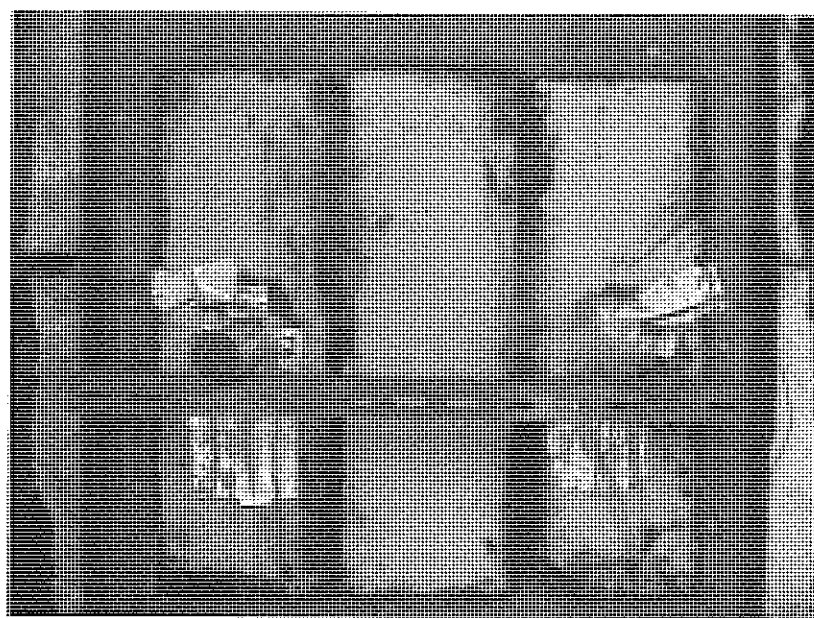

圖 15 測試 60min 時試件背火面

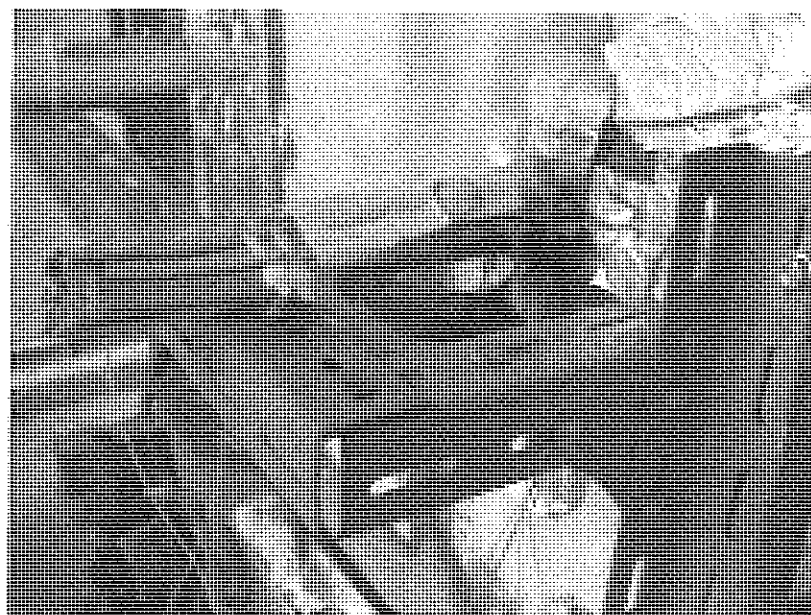

圖 16 測試 90min 時試件背火面

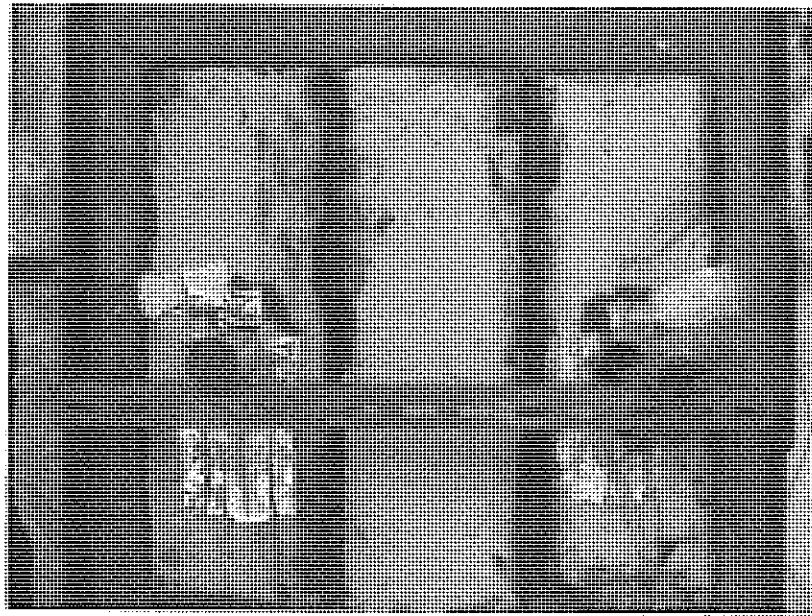

圖 17 測試 120min 時試件背火面



圖 18 測試 180min 時試件背火面

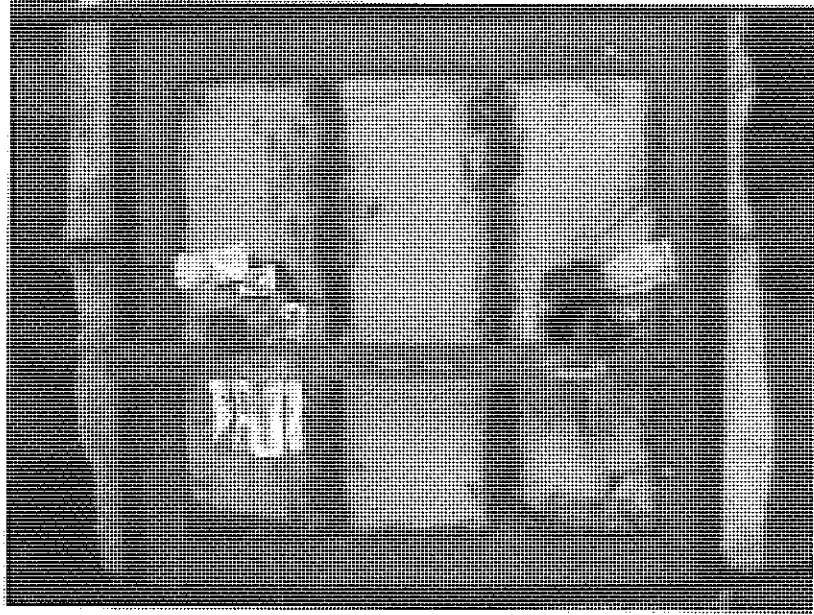

圖 19 測試 210min 時試件背火面



圖 20 測試 240min 時試件背火面



圖 21 測試後試件向火面

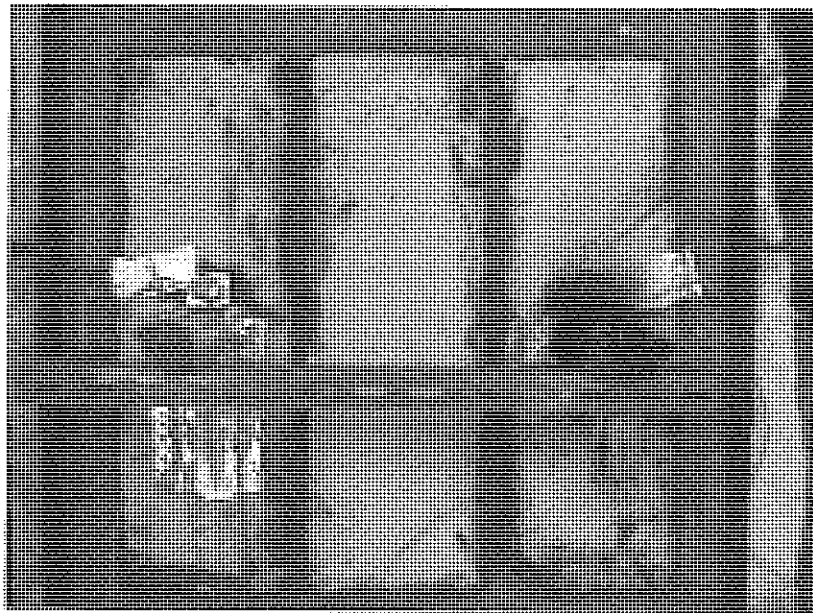

圖 22 測試後試件向火面過牆大樣圖(一)

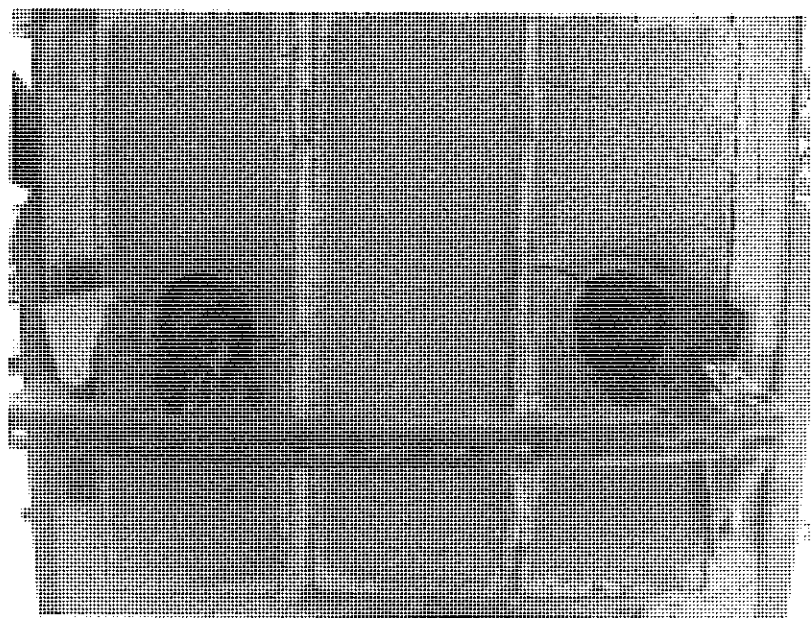

圖 23 測試後試件向火面過牆大樣圖(二)

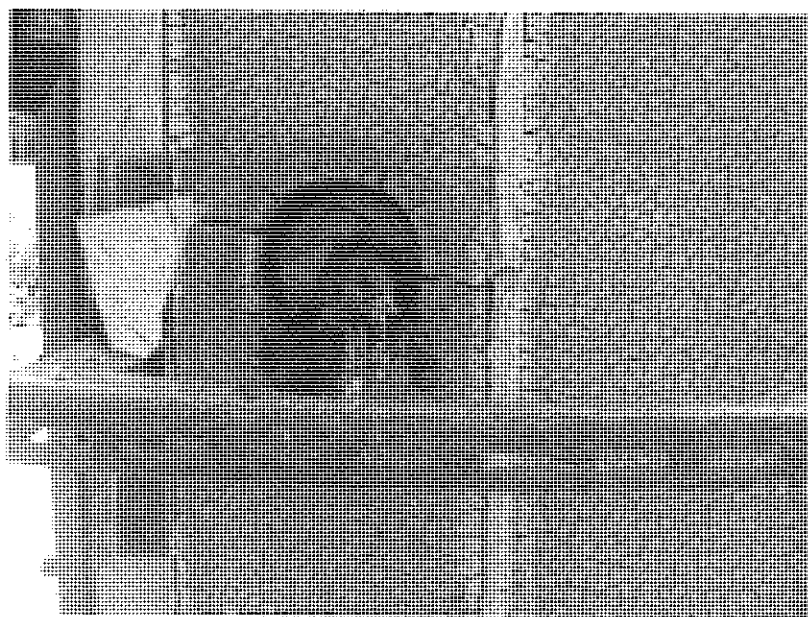

評估報告

No. 2015-A15

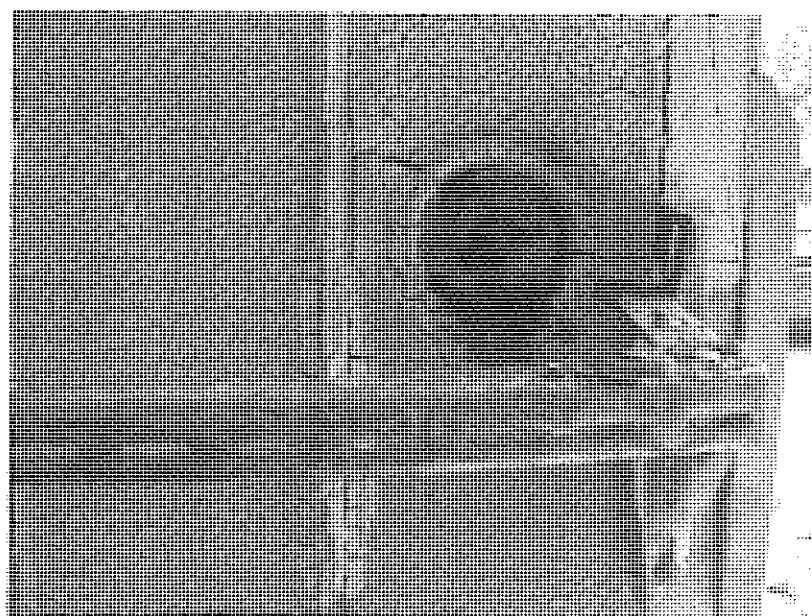
產品名稱: FS-ONE MAX Firestop Sealant
(原檢測報告編號: 2006-FRT20)

報告發送致送檢單位:

送檢單位: Hilti (Hong Kong) Limited

報告日期: 2015年04月20日

複檢日期: 2018年04月20日



評估報告

No: 2015-A15

產品名稱	FS-ONE MAX Firestop Sealant (原檢測報告編號: 2006-FRT20)
送檢單位名稱	Hilti (Hong Kong) Limited
製造商	Hilti (Hong Kong) Limited
產地	德國
樣本型號規格	密度: 1500kg/m ³ (±10%) 顏色: 紅色 施工溫度: +5°C 至 +40°C 施工時間: Approx 20 min (@23°C / 50% rh) 固化速度: 4mm / 3 日 容許變形: ±5%
送檢文件	FS-ONE 及 FS-ONE MAX 參數比較資料表 廠方發出的澄清文件 FS-ONE MAX 的 UL 認證 (No. 20150108-R13240)
評估項目	耐火性能
評估標準	BS476:Part 20
文件送檢日期	2015 年 04 月 13 日
評估結論	經審閱送檢文件後，評定此膨脹性防火泥膠按原檢測報告的結構下，此膨脹性防火泥膠的完整性能達到 240 分鐘，而隔熱性則能達到 46 分鐘。

檢測人員，

審核，

黃傑勇
實驗員

譚立武
澳門大學機電工程系教授
澳門發展及質量研究所董事局主席

1. 評估目的

此評估報告是針對送檢單位 Hilti (Hong Kong) Limited 生產的 FS-ONE MAX Firestop Sealant 及提交由澳門大學所進行的檢測報告編號: 2006-FRT20 進行評估，並以文件審閱的方式來判斷此 FS-ONE MAX Firestop Sealant，是否仍達到英國標準 BS476 第 20 部份:1987 判斷之耐火性能。

2. 評估假設

此評估報告內膨脹性防火泥膠的安裝方式應與送檢單位之前所送檢的膨脹性防火泥膠一致，並具有相同的質量。同時用作固定周邊的結構必須有足夠的支撐能力。送檢單位需確認所有提交資料的準確性及真確性，如發現相關情況實，本評估報告將即時無條件地失效並隨即以信件形式通知送檢單位。

3. FS-ONE MAX 資料

根據檢測報告編號: 2006-FRT20、FS-ONE 目錄、廠方發出的 FS-ONE 參數資料表及澄清文件中顯示，Hilti (Hong Kong) Limited 生產的 FS-ONE 膨脹性防火泥膠的隔熱性能達到 46 分鐘，而完整性能達到 240 分鐘的防火效能，其中的主要的參數如下:

項目	物料	描述
1.	Chemical Basis	Water-based acrylic dispersion
2.	Density	1500 kg/m ³ (±10%)
3.	Application Temperature	5 °C to 40 °C (41 °F to 104 °F)
4.	Temperature Resistance (Cured)	-40 °C to 100 °C (-104 °F to 212 °F)
5.	Approximate Cure Time	Approx. 4 mm / 3 days
6.	Expansion Temperature	Starting at approx. 220 °C (428 °F)
7.	Expansion Rate (Unrestricted)	1:5
8.	Shore A Hardness	77
9.	Surface Burning Characteristics	Flame Spread : 0 Smoke Development : 5 (ASTM E84)
10.	Sound Transmission Classification	56 (relates to specific construction) (ASTM E90)
11.	Mold & Mildew Performance	Mold & Mildew resistant Class 0 (ASTM G21)
12.	Shelf Life After Production	9 months



根據送檢單位所提交的 FS-ONE MAX 目錄、廠方發出的 FS-ONE MAX 參數資料表及澄清文件中顯示，所需評估的 FS-ONE MAX 膨脹性防火泥膠的主要參數如下：

項目	物料	描述
1.	Chemical Basis	Water-based acrylic dispersion
2.	Density	1500 kg/m ³ (±10%)
3.	Application Temperature	5 °C to 40 °C (41 °F to 104 °F)
4.	Temperature Resistance (Cured)	-20 °C to 100 °C (-68 °F to 212 °F)
5.	Approximate Cure Time	Approx. 4 mm / 3 days
6.	Expansion Temperature	Starting at approx. 150 °C (302 °F)
7.	Expansion Rate (Unrestricted)	1:5
8.	Shore A Hardness	50
9.	Surface Burning Characteristics	Flame Spread : 0 Smoke Development : 10 (ASTM E84)
10.	Sound Transmission Classification	62 (relates to specific construction) (ASTM E90)
11.	Mold & Mildew Performance	Mold & Mildew resistant Class 0 (ASTM G21)
12.	Shelf Life After Production	12 months

4. 參數之評估

4.1 Chemical Basis:

FS-ONE MAX 膨脹性防火泥膠與 FS-ONE 膨脹性防火泥膠均為 Water-based acrylic dispersion，為相同的物料。

4.2 Density

FS-ONE MAX 膨脹性防火泥膠與 FS-ONE 膨脹性防火泥膠均為 1500 kg/m³ (± 10%)。

4.3 Application Temperature:

FS-ONE MAX 膨脹性防火泥膠與 FS-ONE 膨脹性防火泥膠均為 5°C to 40°C (41°F to 104°F)。

4.4 Temperature Resistance (Cured) :

FS-ONE MAX 膨脹性防火泥膠為 -20°C to 100°C (-68°F to 212°F)，FS-ONE 膨脹性防火泥膠為 -40°C to 100°C (-104°F to 212°F)，雖然 FS-ONE MAX 膨脹性防火泥膠的最低溫度不及 FS-ONE 膨脹性防火泥膠的 -40°C，但根據廠方發出的參數比較資料表上顯示仍能符合 ASTM C834 Type C Grade -18°C，且於澳門地區的使用防火填充物料，較少應用於 -20°C 以下的場所。

4.5 Approximate Cure Time:

FS-ONE MAX 膨脹性防火泥膠與 FS-ONE 膨脹性防火泥膠均為 Approx. 4 mm / 3 days。

4.6 Expansion Temperature:

FS-ONE MAX 膨脹性防火泥膠為 Starting at approx. 150 °C (302 °F)，FS-ONE 膨脹性防火泥膠為 Starting at approx. 220 °C (428 °F)，FS-ONE MAX 膨脹性防火泥膠能於較低溫度下開始膨脹。

4.7 Expansion Rate (Unrestricted) :

FS-ONE MAX 膨脹性防火泥膠與 FS-ONE 膨脹性防火泥膠均為 1:5。

4.8 Shore A Hardness:

FS-ONE MAX 膨脹性防火泥膠為 50，FS-ONE 膨脹性防火泥膠為 77，根據廠方發出的澄清文件，FS-ONE MAX 膨脹性防火泥膠比較軟，能比較容易使用。

4.9 Surface Burning Characteristics:

FS-ONE MAX 膨脹性防火泥膠與 FS-ONE 膨脹性防火泥膠均為 Flame Speed : 0 ;

FS-ONE MAX 膨脹性防火泥膠為 Smoke Development : 10，FS-ONE 膨脹性防火泥膠為 Smoke Development : 5 ;

雖然 FS-ONE MAX 膨脹性防火泥膠煙產生指數比 FS-ONE 膨脹性防火泥膠較多，但根據廠方發出的澄清文件，於 IBC Code 2006 中，FS-ONE MAX 膨脹性防火泥膠與 FS-ONE 膨脹性防火泥膠的火焰蔓延及煙產生指數均分類為同一等級 Class A。

4.10 Sound Transmission Classification:

於特定的結構下，FS-ONE MAX 膨脹性防火泥膠為 62，FS-ONE 膨脹性防火泥膠為 56，FS-ONE MAX 膨脹性防火泥膠的隔音性能較佳。

4.11 Mold & Mildew Performance:

FS-ONE MAX 膨脹性防火泥膠與 FS-ONE 膨脹性防火泥膠均為 Mold & Mildew resistant Class 0。

4.12 Shelf Life After Production:

FS-ONE MAX 膨脹性防火泥膠為 12 months，FS-ONE 膨脹性防火泥膠為 9 months，FS-ONE MAX 膨脹性防火泥膠的性能較佳。

5. 結論

按照送檢單位提交之 FS-ONE 及 FS-ONE MAX 參數比較資料表、廠方發出的澄清文件、FS-ONE 及 FS-ONE MAX 的目錄，經本實驗室審閱送檢文件後，認為此膨脹性防火泥膠按原檢測報告的結構下，此膨脹性防火泥膠的隔熱性能達到 46 分鐘，而完整性能達到 240 分鐘。

6. 評估之有效性

澳門大學之聲明：

- 本報告之評估是建基於送檢單位之送檢資料，如發現資料不實，本報告將無條件地失效。
- 由於此報告是根據文件進行評估，如日後此產品型號再進行符合相關標準之測試，如結論有任何差異，將會以測試結果為準。
- 本報告有效期為 3 年，在期限以後應再次進行評估，如有任何額外資料補充，會考慮對本報告作出更新，過期而沒有收到送檢單位或廠提交之更新資料時，本報告亦將無條件地失效。



澳門特別行政區政府
 Governo da Região Administrativa Especial de Macau
 消防局
 Corpo de Bombeiros

頁編號 1/1
 Pág. n.
 文件編號 1199/DT/2006
 Inf. n.
 日期: 27 / 06 / 2006
 Data

審閱 (Visto)
 於 Em 07/07/2006
 技術廳廳長
 O Chefe do D.T.

意見書

事由：要求審批“HILTI”喜利得防火延燒產品 –FS ONE Firestop Sealant

參件：進入編號 7272 (12/06/2006)
 喜利得(香港)有限公司來函編號：M-AL_LE11_06(12/06/2006)
 意見書編號:1198/DT/2006

- Ø1. 根據上述公司交來的資料分析後，由 FS ONE Firestop Sealant (膨脹性防火泥膠)組成的試件組合於試驗結果中顯示具 CRF46 能力。然而，如將此組件應用於不同組合型式使用時，應按照實際用途而作出相應評估。
- Ø2. 本局對 FS ONE Firestop Sealant (膨脹性防火泥膠)使用於合符《防火安全規章》規範的標準時沒有異議。但最終決定仍須徵詢權限部門(土地工務運輸局)之意見。

備註：上述試件組合試驗結果的耐火能力(CRF)，並不代表 FS ONE Firestop Sealant (膨脹性防火泥膠)所具有之耐火能力(CRF)，產品使用時應按照產品說明書內的特定應用範圍使用。

二零零六年七月三日，於技術廳研究暨試驗科

研究暨試驗科科長

鍾兆豐
 副消防區長



Certificate of Compliance

This certificate is issued for the following:

FS-ONE MAX Intumescent Firestop Sealant for use in floor assemblies

Prepared for:

Hilti Inc
5400 S 122nd E Ave
PO Box 21148
Tulsa, OK 74146
United States

FM Approvals Class: 4990

Approval Identification: 3054773

Approval Granted: 1-23-15

To verify the availability of the Approved product, please refer to www.approvalguide.com or www.roofnav.com

Said Approval is subject to satisfactory field performance, continuing Surveillance Audits, and strict conformity to the constructions as shown in the Approval Guide, an online resource of FM Approvals.

A handwritten signature in dark ink that reads 'Cynthia E Frank'.

Cynthia Frank
AVP - Manager of Materials
FM Approvals
1151 Boston-Providence Turnpike
Norwood, MA 02062



Member of the FM Global Group

CERTIFICATE OF COMPLIANCE

Certificate Number 20150108-R13240
Report Reference R13240
Issue Date 2015-January-08

Issued to: Hilti Construction Chemicals, Div of Hilti Inc.
5400 S 122nd East Ave
Tulsa, OK 74146

**This is to certify that
representative samples of**

Fill, Void or Cavity Materials
Fill, Void or Cavity Materials Certified for Canada
FS-ONE MAX Intumescent Sealant for use in Through-
Penetration Firestop and Joint Systems in the UL Fire
Resistance Directory and in the Products Certified for
Canada Directory.

Have been investigated by UL in accordance with the
Standard(s) indicated on this Certificate.

Standard(s) for Safety: ANSI/UL 1479, "Fire Tests of Through-Penetration
Firestops," – Edition 4
ANSI/UL 2079, "Tests for Fire Resistance of Building Joint
Systems," – Edition 4 – Revision Date 2014/12/17
CAN/ULC-S115, "Standard Method of Fire Tests of Firestop
Systems." – Edition 4 – Issue Date 2011/06/01

Additional Information: See the UL Online Certifications Directory at
www.ul.com/database for additional information

Only those products bearing the UL Classification Mark should be considered as being covered by
UL's Classification and Follow-Up Service.

The UL Classification Mark includes: UL in a circle: with the word "CLASSIFIED"  (as shown); a control
number (may be alphanumeric) assigned by UL; a statement to indicate the extent of UL's evaluation of
the product; and the product category name (product identity) as indicated in the appropriate UL
Directory.

Look for the UL Classification Mark on the product.

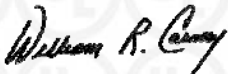

William R. Carney, Director, North American Certification Programs

UL LLC

Any information and documentation involving UL Mark services are provided on behalf of UL LLC (UL) or any authorized licensee of UL. For questions, please
contact a local UL Customer Service Representative at www.ul.com/contactus



Attn. : To whom it may concern

Date : 18th March 2015

Ref. : LE/JT/13015

Subject : Hilti FS-ONE MAX High Performance Intumescent Firestop Sealant

Dear Sirs / Madams,

Enclosed please find the information of Hilti FS-ONE MAX High Performance Intumescent Firestop Sealant

Brand Name : Hilti

Model Name : Hilti FS-ONE MAX High Performance Intumescent Firestop Sealant

Manufacturer : Hilti Corporation

Address of Manufacturer : FL-9494, Principality of Liechtenstein.

Supplier : Hilti (Hong Kong) Ltd

Address of Supplier : 701-704 & 708A&B, 7/F, Tower A, Manulife Financial Centre,
223 Wai Yip Street, Kwun Tong, Kowloon, Hong Kong.

Country of Origin : Germany

Should you have further questions, please do not hesitate to contact our Technical Representatives or Customer Service Hotline at 8228-8118.

Yours sincerely,

Hilti (Hong Kong) Ltd.



Andrew Lau

Product Manager



December 19, 2014

To Whom It May Concern:

Re: Hilti FS-ONE Max Firestop – LEED Info.

The Hilti FS-ONE MAX Firestop is manufactured in Germany.

There is no post-consumer or post-industrial content in FS-ONE MAX and it cannot be recycled. The VOC content for FS-ONE MAX is 9 grams/liter.

FS-ONE MAX is not regulated as a hazardous waste by the Federal EPA Standards. The regulations for the disposal of non-regulated industrial waste can vary from state to state and even city to city. For this reason, you should consult your local and state regulatory agencies for direction on disposal.

Please feel free to contact me at (918) 872-3704 if you have questions.

Sincerely,

A handwritten signature in black ink, which appears to read "Jerry Metcalf". The signature is written in a cursive style.

Jerry Metcalf MPH, CHMM
Sr. Mgr. Safety/Environmental
Hilti Inc
(918) 872 3704
jerry.metcalf@hilti.com

Rev. Date: 12/19/14

Hilti, Inc.
5400 South 122nd East Avenue
Tulsa, OK 74146

1-800-879-8000
www.hilti.com

1 Identification

- **Product identifier**
- **Trade name:** **FS-ONE MAX**
- **Relevant identified uses of the substance or mixture and uses advised against** No further relevant information available.
- **Application of the substance / the mixture** Construction chemicals
- **Details of the supplier of the safety data sheet**
- **Manufacturer/Supplier:**
Hilti, Inc.
5400 South 122nd East Ave.
US-Tulsa, OK 74146
Phone: (800) 879-8000
Fax: (800) 879-7000
Español: (800) 879-5000
- **Information department:**
chemicals.hse@hilti.com
see section 16
- **Emergency telephone number:**
Chem-Trec
Tel.: 1 800 424 9300

2 Hazard(s) identification

- **Classification of the substance or mixture** The product is not classified according to the Globally Harmonized System (GHS).
- **Label elements**
- **GHS label elements** Void
- **Hazard pictograms** Void
- **Signal word** Void
- **Hazard statements** Void
- **Classification system**
- **NFPA ratings (scale 0-4)**



- **Other hazards**
- **Results of PBT and vPvB assessment**
- **PBT:** Not applicable.
- **vPvB:** Not applicable.

3 Composition/information on ingredients

- **Chemical characterization: Mixtures**
- **Description:** .
- **Dangerous components:** Void
- **Additional information** For the wording of the listed risk phrases refer to section 16.

4 First-aid measures

- **Description of first aid measures**
- **General information** No special measures required.
- **After inhalation** Take affected persons into fresh air and keep quiet.
- **After skin contact** Immediately wash with water and soap and rinse thoroughly.
- **After eye contact** Rinse opened eye for several minutes under running water. Then consult a doctor.
- **After swallowing** Seek immediate medical advice.
- **Most important symptoms and effects, both acute and delayed** No further relevant information available.
- **Indication of any immediate medical attention and special treatment needed** No further relevant information available.

5 Fire-fighting measures

- **Extinguishing media**
- **Suitable extinguishing agents** CO₂, extinguishing powder or water spray. Fight larger fires with water spray or alcohol resistant foam.
- **Special hazards arising from the substance or mixture**
In case of fire, the following can be released:
Carbon monoxide (CO)
Carbondioxide (CO₂)
- **Advice for firefighters**
- **Protective equipment:** Ensure adequate ventilation

Trade name: FS-ONE MAX

(Contd. of page 1)

6 Accidental release measures

- **Personal precautions, protective equipment and emergency procedures**
 - Ensure adequate ventilation
 - Wear protective clothing.
 - Particular danger of slipping on leaked/spilled product.
- **Environmental precautions:** Do not allow product to reach sewage system or any water course.
- **Methods and material for containment and cleaning up:**
 - Pick up mechanically.
 - Dispose contaminated material as waste according to item 13.
- **Reference to other sections**
 - See Section 7 for information on safe handling
 - See Section 8 for information on personal protection equipment.
 - See Section 13 for disposal information.

7 Handling and storage

- **Precautions for safe handling** No special measures required.
- **Information about protection against explosions and fires:** No special measures required.
- **Conditions for safe storage, including any incompatibilities**
- **Storage**
- **Requirements to be met by storerooms and receptacles:** keep containers securely closed and dry, store at 5 - 25 °C / 41 - 77 °F
- **Information about storage in one common storage facility:** Not required.
- **Further information about storage conditions:** None.
- **Storage class** 10
- **Specific end use(s)** No further relevant information available.

8 Exposure controls/personal protection

- **Control parameters**
- **Components with limit values that require monitoring at the workplace:**
 - The product does not contain any relevant quantities of materials with critical values that have to be monitored at the workplace.
- **Additional information:** The lists that were valid during the creation were used as basis.
- **Exposure controls**
- **Personal protective equipment**
- **General protective and hygienic measures**
 - The usual precautionary measures for handling chemicals should be followed.
 - Avoid contact with the eyes and skin.
 - Keep away from foodstuffs, beverages and feed.
 - Wash hands before breaks and at the end of work.
- **Breathing equipment:** Not necessary if room is well-ventilated.
- **Protection of hands:**



Protective gloves.

The glove material has to be impermeable and resistant to the product/ the substance/ the preparation.
Selection of the glove material on consideration of the penetration times, rates of diffusion and the degradation
EN 374

- **Material of gloves**

Synthetic gloves

The selection of the suitable gloves does not only depend on the material, but also on further marks of quality and varies from manufacturer to manufacturer. As the product is a preparation of several substances, the resistance of the glove material can not be calculated in advance and has therefore to be checked prior to the application.

- **Penetration time of glove material**

The exact break through time has to be found out by the manufacturer of the protective gloves and has to be observed.

- **For the permanent contact gloves made of the following materials are suitable:** Nitrile rubber, NBR

- **Eye protection:**



Tightly sealed goggles.

EN 166 + EN 170

(Contd. on page 3)

Trade name: FS-ONE MAX

(Contd. of page 2)

· Body protection:



Protective work clothing.

9 Physical and chemical properties

· Information on basic physical and chemical properties

· General Information

· Appearance:

Form: Pasty

Color: Red

· Odor: Characteristic

· Odour threshold: Not determined.

· pH-value: Not determined.

· Change in condition

Melting point/Melting range: Not determined.

Boiling point/Boiling range: 100 °C (212 °F)

· Flash point: Not applicable

· Flammability (solid, gaseous) Not applicable.

· Ignition temperature:

Decomposition temperature: Not determined.

· Auto igniting: Product is not selfigniting.

· Danger of explosion: Product does not present an explosion hazard.

· Explosion limits:

Lower: Not determined.

Upper: Not determined.

· Vapor pressure at 20 °C (68 °F): 23 hPa (17 mm Hg)

· Density: Not determined

· Relative density Not determined.

· Vapour density Not determined.

Not applicable.

· Evaporation rate Not determined.

· Solubility in / Miscibility with

Water: Not miscible or difficult to mix

· Partition coefficient (n-octanol/water): Not determined.

· Viscosity:

dynamic: Not determined.

kinematic: Not determined.

· Solvent content:

Organic solvents: 1.0 %

Water: 18.5 %

· Other information No further relevant information available.

10 Stability and reactivity

· Reactivity

· Chemical stability

· Thermal decomposition / conditions to be avoided: No decomposition if used according to specifications.

· Possibility of hazardous reactions No dangerous reactions known

· Conditions to avoid No further relevant information available.

· Incompatible materials: No further relevant information available.

· Hazardous decomposition products: No dangerous decomposition products known

11 Toxicological information

· Information on toxicological effects

· Acute toxicity:

· Primary irritant effect:

· on the skin: No irritant effect.

· on the eye: No irritating effect.

· Sensitization: No sensitizing effects known.

(Contd. on page 4)

Trade name: FS-ONE MAX

(Contd. of page 3)

Additional toxicological information:

When used and handled according to specifications, the product does not have any harmful effects according to our experience and the information provided to us.

IARC (International Agency for Research on Cancer)

None of the ingredients is listed.

NTP (National Toxicology Program)

None of the ingredients is listed.

OSHA-Ca (Occupational Safety & Health Administration)

None of the ingredients is listed.

12 Ecological information**Toxicity**

- **Aquatic toxicity:** No further relevant information available.
- **Persistence and degradability** No further relevant information available.
- **Bioaccumulative potential** No further relevant information available.
- **Mobility in soil** No further relevant information available.
- **Results of PBT and vPvB assessment**
- **PBT:** Not applicable.
- **vPvB:** Not applicable.
- **Other adverse effects** No further relevant information available.

13 Disposal considerations

- **Waste treatment methods**
- **Recommendation** Must not be disposed of together with household garbage. Do not allow product to reach sewage system.
- **European waste catalogue:**
08 00 00
08 04 00
08 04 10
- **Uncleaned packagings:**
- **Recommendation:** Dispose of packaging according to regulations on the disposal of packagings.

14 Transport information

- | | |
|--|-----------------|
| · UN-Number | Void |
| · DOT, ADR, ADN, IMDG, IATA | Void |
| · UN proper shipping name | Void |
| · DOT, ADR, ADN, IMDG, IATA | Void |
| · Transport hazard class(es) | |
| · DOT, ADR, ADN, IMDG, IATA | Void |
| · Class | Void |
| · Packing group | Void |
| · DOT, ADR, IMDG, IATA | Void |
| · Environmental hazards: | |
| · Marine pollutant: | No |
| · Special precautions for user | Not applicable. |
| · Transport in bulk according to Annex II of MARPOL73/78 and the IBC Code | Not applicable. |
| · UN "Model Regulation": | - |

15 Regulatory information

- **Safety, health and environmental regulations/legislation specific for the substance or mixture**
- **Sara**

Section 355 (Extremely hazardous substances):

None of the ingredients is listed.

Section 313 (Specific toxic chemical listings):

None of the ingredients are listed.

TSCA (Toxic Substances Control Act):

All ingredients are listed.

(Contd. on page 5)



Material Safety Data Sheet

acc. to ISO 11014

Printing date 09/18/2014

Version number 1

Reviewed on 09/18/2014

Trade name: FS-ONE MAX

(Contd. of page 4)

· **Proposition 65:**

· **Chemicals known to cause cancer:**

None of the ingredients are listed.

· **Carcinogenicity categories**

· **EPA (Environmental Protection Agency)**

None of the ingredients is listed.

· **TLV (Threshold Limit Value established by ACGIH)**

None of the ingredients is listed.

· **MAK (German Maximum Workplace Concentration)**

None of the ingredients is listed.

· **NIOSH-Ca (National Institute for Occupational Safety and Health)**

None of the ingredients is listed.

· **National regulations**

· **Information about limitation of use:** Employment restrictions concerning young persons must be observed.

· **Chemical safety assessment:** not required.

16 Other information

This information is based on our present knowledge. However, this shall not constitute a guarantee for any specific product features and shall not establish a legally valid contractual relationship.

· **Department issuing SDS:**

Hilti Corporation
Business Unit Chemicals
Quality/Safety/Environment
FL-9494 Schaan / Liechtenstein

chemicals.hse@hilti.com

Tel.: +423 234 3004

FAX.: +423 234 3462

· **Date of preparation / last revision** 09/18/2014 / -

· **Abbreviations and acronyms:**

ADR: Accord européen sur le transport des marchandises dangereuses par Route (European Agreement concerning the International Carriage of Dangerous Goods by Road)

IMDG: International Maritime Code for Dangerous Goods

DOT: US Department of Transportation

IATA: International Air Transport Association

ACGIH: American Conference of Governmental Industrial Hygienists

EINECS: European Inventory of Existing Commercial Chemical Substances

ELINCS: European List of Notified Chemical Substances

CAS: Chemical Abstracts Service (division of the American Chemical Society)

NFPA: National Fire Protection Association (USA)

· *** Data compared to the previous version altered.**

US



Job / Application Reference

<u>Date</u>	<u>Project Name</u>	<u>Contractor</u>	<u>Product Name</u>	<u>Application</u>
May-14	Galaxy Mega Resort (Phase 2)	Hsin Chong	Firestop sealant FS-ONE 10.10Z CART	cable penetration sealing
May-14	Shangri-la and Traders Hotels Sheraton and St. Regis Hotels (Parcel 5&6)		Firestop sealant FS-ONE 10.10Z CART	electrical penetration through fire rated board
Mar-14	Wynn Palace	LEIGHTON CONTRACTORS (ASIA) LIMITED	Firestop sealant FS-ONE 10.10Z CART	fire sealing of openings
Jan-14	Others Civil Projects in Macau (incl. Utilities)		Firestop sealant FS-ONE 10.10Z CART	water pipe / pipe duct fixing
Mar-13	Others Commercial Projects in Macau		Firestop sealant FS-ONE 10.10Z CART	air duct penetration through fire rated board
Dec-12	The Venetian Casino Resort		Firestop sealant FS-ONE 10.10Z CART	cable / cable tray penetraton sealing
Aug-12	The Venetian Casino Resort		Firestop sealant FS-ONE 10.10Z CART	sealing inside electrical trucking
Aug-12	The Venetian Casino Resort		Firestop sealant FS-ONE 10.10Z CART	sealing inside electrical trucking
Aug-12	The Venetian Casino Resort		Firestop sealant FS-ONE 10.10Z CART	UPVC pipe penetration sealing

Job/Application Reference (FS-One)



<u>Year</u>	<u>Project</u>	<u>Contractor</u>	<u>Product</u>	<u>Application</u>
09.2011	Venetian Casino Parcel 5&6	HONEYWELL (MACAU) LTD	FS-One	Trunking penetration
04.2012	Wynn Resort	SUN TAT FIRE ENG CO LTD	FS-One	Plastic pipe penetration
06.2012	Wynn Resort	CDI INTERNATIONAL LIMITED	FS-One	Plastic conduit penetration

Job/Application Reference

08-Jan-09



<u>Ref No</u>	<u>Date</u>	<u>Project</u>	<u>Contractor</u>	<u>Consulting Engineer</u>	<u>Product</u>	<u>Application</u>
15016	08-07	Las Vegas Sands Casino Extension, Macau	NORTH SEA (MACAU) ENGINEERING LTD.	OAP / PBA / Arup Façade	Firestop sealant FS-ONE 10.10Z CART	sealing inside electrical trucking
10997	03-07	The Venetian Casino Resort, Macau	HITACHI ELEVATOR ENG CO (HK) LTD	OAP / PBA / Hyder / Arup Façade	Firestop sealant FS-ONE 10.10Z CART	lift / escalator fixing
10764	03-07	The Venetian Casino Resort, Macau	KAM LON INSTALACOES ELECTRICAS	OAP / PBA / Hyder / Arup Façade	Firestop sealant FS-ONE 10.10Z CART	sealing inside electrical trucking
10701	03-07	The Venetian Casino Resort, Macau	HITACHI ELEVATOR ENG CO (HK) LTD	OAP / PBA / Hyder / Arup Façade	Firestop sealant FS-ONE 10.10Z CART	sealing inside electrical trucking
10464	02-07	The Venetian Casino Resort, Macau	MANSON COMPANHIA DE ENGENHARIA	OAP / PBA / Hyder / Arup Façade	Firestop sealant FS-ONE 10.10Z CART	electrical services fixing
10151	01-07	The Venetian Casino Resort, Macau	COMPANHIA DE ENGENHARIA ALISON	OAP / PBA / Hyder / Arup Façade	Firestop sealant FS-ONE 10.10Z CART	sealing inside electrical trucking
9765	01-07	The Venetian Casino Resort, Macau	PCCW (MACAU) LIMITED	OAP / PBA / Hyder / Arup Façade	Firestop sealant FS-ONE 10.10Z CART	sealing inside electrical trucking
7578	12-06	The Venetian Casino Resort, Macau	SHUN TAI ELECT ENG CO LTD	OAP / PBA / Hyder / Arup Façade	Firestop sealant FS-ONE 10.10Z CART	cable / cable tray penetration sealing
8805	09-06	The Venetian Casino Resort, Macau	ATAL ENGINEERING(MACAO) LTD	OAP / PBA / Hyder / Arup Façade	Firestop sealant FS-ONE 10.10Z CART	Metal pipe penetration sealing
7611	07-06	The Venetian Casino Resort, Macau	SHINRYO HONG KONG (MACAU BRANCH)	OAP / PBA / Hyder / Arup Façade	Firestop sealant FS-ONE 10.10Z CART	cable protection
7609	07-06	The Venetian Casino Resort, Macau	SHINRYO (HK) LTD	OAP / PBA / Hyder / Arup Façade	Firestop sealant FS-ONE 10.10Z CART	cable protection
8951	03-06	The Venetian Casino Resort, Macau	GTECH ENGINEERING (MACAU) LTD	OAP / PBA / Hyder / Arup Façade	Firestop sealant FS-ONE 10.10Z CART	Metal pipe penetration sealing