





Hilti HIT-HY 200 with HIT-Z

Injection mortar system		Benefits
	Hilti HIT-HY 200-A 500 ml foil pack (also available as 330 ml foil pack)	<ul style="list-style-type: none"> - No cleaning required: Zero susceptibility to borehole cleaning conditions with dry and water saturated concrete base material - Maximum load performance in cracked concrete and uncracked concrete - Suitable for cracked and non-cracked concrete C 20/25 to C 50/60 - Suitable for use with diamond cored holes in non-cracked or cracked concrete with no load reductions - Two mortar (Hilti HIT-HY 200-A and Hilti HIT-HY 200-R) versions available with different curing times and same performance - seismic application (C1/C2)
	Hilti HIT-HY 200-R 500 ml foil pack (also available as 330 ml foil pack)	
	Static mixer	
	HIT-Z HIT-Z-R rod	



Concrete



Tensile zone



Seismic



Corrosion resistance



European Technical Approval



CE conformity



PROFIS Anchor design software



No cleaning required for approved loads

Approvals / certificates

Description	Authority / Laboratory	No. / date of issue
European technical approval ^{a)}	DIBt, Berlin	ETA-12/0006 / 2013-03-15 (HIT-HY 200-A) ETA-12/0028 / 2013-03-15 (HIT-HY 200-R)
Fire test report	IBMB, Brunswick	3501/676/13 / 2012-08-03

a) All data given in this section according ETA-12/0006 and ETA-12/0028, issue 2013-03-15.

Basic loading data (for a single anchor)

All data in this section applies to

- Correct setting (See setting instruction)
- No edge distance and spacing influence
- Steel failure
- Base material thickness, as specified in the table
- Embedment depth, as specified in the table
- One anchor material, as specified in the tables
- Concrete C 20/25, $f_{ck,cube} = 25 \text{ N/mm}^2$
- Temperature range I
(min. base material temperature -40°C , max. long term/short term base material temperature: $+24^\circ\text{C}/40^\circ\text{C}$)
- Installation temperature range $+5^\circ\text{C}$ to $+40^\circ\text{C}$

For details see Simplified design method

Embedment depth and base material thickness for the basic loading data. Mean ultimate resistance, characteristic resistance, design resistance, recommended loads.

Anchor size	M8	M10	M12	M16	M20
Typical embedment depth [mm]	70	90	110	145	180
Base material thickness [mm]	130	150	170	245	280

Characteristic resistance: concrete C 20/25 – $f_{ck,cube} = 25 \text{ N/mm}^2$, element HIT-Z / HIT-ZR

Anchor size			M8	M10	M12	M16	M20
Non-cracked concrete							
Tensile N_{Rk}	HIT-Z	[kN]	24,0	38,0	54,3	88,2	122,0
Shear V_{Rk}	HIT-Z	[kN]	12,0	19,0	27,0	48,0	73,0
Tensile N_{Rk}	HIT-ZR A4	[kN]	24,0	38,0	54,3	88,2	122,0
Shear V_{Rk}	HIT-ZR A4	[kN]	14,0	23,0	33,0	57,0	88,0
Cracked concrete							
Tensile N_{Rk}	HIT-Z	[kN]	21,1	30,7	41,5	62,9	86,9
Shear V_{Rk}	HIT-Z	[kN]	12,0	19,0	27,0	48,0	73,0
Tensile N_{Rk}	HIT-ZR A4	[kN]	21,1	30,7	41,5	62,9	86,9
Shear V_{Rk}	HIT-ZR A4	[kN]	14,0	23,0	33,0	57,0	88,0

Design resistance: concrete C 20/25 – $f_{ck,cube} = 25 \text{ N/mm}^2$, element HIT-Z / HIT-ZR

Anchor size			M8	M10	M12	M16	M20
Non-cracked concrete							
Tensile N_{Rd}	HIT-Z	[kN]	16,0	25,3	36,2	58,8	81,3
Shear V_{Rd}	HIT-Z	[kN]	9,6	15,2	21,6	38,4	58,4
Tensile N_{Rk}	HIT-ZR A4	[kN]	19,7	28,7	36,3	58,8	81,3
Shear V_{Rk}	HIT-ZR A4	[kN]	11,2	18,4	26,4	45,6	70,4
Cracked concrete							
Tensile N_{Rd}	HIT-Z	[kN]	14,1	20,5	27,7	41,9	58,0
Shear V_{Rd}	HIT-Z	[kN]	9,6	15,2	21,6	38,4	58,4
Tensile N_{Rk}	HIT-ZR A4	[kN]	14,1	20,5	27,7	41,9	58,0
Shear V_{Rk}	HIT-ZR A4	[kN]	11,2	18,4	26,4	45,6	70,4

Recommended loads ^{a)}: concrete C 20/25 – $f_{ck,cube} = 25 \text{ N/mm}^2$, element HIT-Z / HIT-ZR

Anchor size			M8	M10	M12	M16	M20
Non-cracked concrete							
Tensile N_{rec}	HIT-Z	[kN]	8,0	12,7	18,1	29,4	40,7
Shear V_{rec}	HIT-Z	[kN]	4,0	6,3	9,0	16,0	24,3
Tensile N_{Rk}	HIT-ZR A4	[kN]	8,0	12,7	18,1	29,4	40,7
Shear V_{Rk}	HIT-ZR A4	[kN]	4,6	7,6	11,0	19,0	29,3
Cracked concrete							
Tensile N_{rec}	HIT-Z	[kN]	7,0	10,2	13,8	20,9	29,0
Shear V_{rec}	HIT-Z	[kN]	4,0	6,3	9,0	16,0	24,3
Tensile N_{Rk}	HIT-ZR A4	[kN]	7,0	10,2	13,8	20,9	29,0
Shear V_{Rk}	HIT-ZR A4	[kN]	4,6	7,6	11,0	19,0	29,3

a) With overall global safety factor $\gamma = 3,0$. The recommended loads vary according to the safety factor requirement from national regulations.

Service temperature range

Hilti HIT-HY 200 injection mortar with anchor rod HIT-Z may be applied in the temperature ranges given below. An elevated base material temperature leads to a reduction of the design bond resistance.

Temperature range	Base material temperature	Maximum long term base material temperature	Maximum short term base material temperature
Temperature range I	-40°C to +40°C	+24°C	+40°C
Temperature range II	-40°C to +80°C	+50°C	+80°C
Temperature range III	-40°C to +120°C	+72°C	+120 °C

Max short term base material temperature

Short-term elevated base material temperatures are those that occur over brief intervals, e.g. as a result of diurnal cycling.

Max long term base material temperature

Long-term elevated base material temperatures are roughly constant over significant periods of time.

Materials

Mechanical properties of HIT-Z and HIT-Z-R

Anchor size		M8	M10	M12	M16	M20
Nominal tensile strength f_{uk}	HIT-Z	650	650	650	610	595
	HIT-Z-R [N/mm ²]					
Yield strength f_{yk}	HIT-Z	520	520	520	490	480
	HIT-Z-R [N/mm ²]					
Stressed cross-section of thread A_s	HIT-Z [mm ²]	36,6	58,0	84,3	157	245
Moment of resistance W	HIT-Z [mm ³]	31,9	62,5	109,7	278	542

Material quality

Part	Material
HIT-Z	C-steel cold formed, steel galvanized $\geq 5\mu\text{m}$
HIT-Z-R	stainless steel cold formed, A4

Anchor dimensions

Anchor size			M8	M10	M12	M16	M20
Length of anchor	min ℓ	[mm]	80	95	105	155	215
	max ℓ	[mm]	120	160	196	240	250
Helix length	ℓ_{Helix}	[mm]	50	60	60	96	100

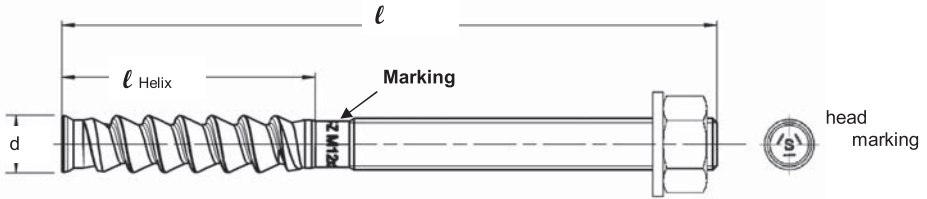

Installation equipment

Anchor size	M8	M10	M12	M16	M20
Rotary hammer	TE 2 – TE 40			TE 40 - TE 70	

Curing and working time

Temperature of the base material	HIT-HY 200-R	
	Working time in which anchor can be inserted and adjusted t_{work}	Curing time before anchor can be loaded t_{cure}
5 °C	1 hour	3 hour
6 °C to 10 °C	40 min	2 hour
11 °C to 20 °C	15 min	1 hour
21 °C to 30 °C	9 min	1 hour
31 °C to 40 °C	6 min	1 hour

Curing and working time

Temperature of the base material	HIT-HY 200-A	
	Working time in which anchor can be inserted and adjusted t_{work}	Curing time before anchor can be loaded t_{cure}
5 °C	25 min	2 hour
6 °C to 10 °C	15 min	1 hour
11 °C to 20 °C	7 min	30 min
21 °C to 30 °C	4 min	30 min
31 °C to 40 °C	3 min	30 min

Setting instruction

Bore hole drilling	
	<p><u>Pre-setting:</u> Drill hole to the required drilling depth with a hammer drill set in rotation-hammer mode using an appropriately sized carbide drill bit. Diamond coring is permissible when diamond core drilling machine and the corresponding core bit are used.</p>
	<p><u>Through-setting:</u> Drill hole through the clearance hole in the fixture to the required drilling depth with a hammer drill set in rotation-hammer mode using an appropriately sized carbide drill bit. Diamond coring is permissible when diamond core drilling machine and the corresponding core bit are used.</p>
Bore hole cleaning^{a)}	
a) No cleaning required for hammer drilled boreholes	
b) Hole flushing and evacuation for wet-drilled diamond cored holes or flooded holes	
	<p>Flush 2 times from the back of the hole over the hole length.</p>
	<p>Blow 2 times the hole with oil-free compressed air (min. 6 bar at 6 m³/h) to evacuate the water</p>
Check of setting depth and compress of the drilling dust	
	<p>Mark the element and check the setting depth and compress the drilling dust. The element has to fit in the hole until the required embedment depth. If it is not possible to compress the dust, remove the dust in the drill hole or drill deeper.</p>

- a) When drilling downward with non-cleaning the required drilling depths can vary due to accumulation of dust in the hole.

Injection preparation

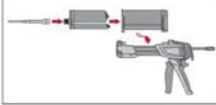

Tightly attach new Hilti mixing nozzle HIT-RE-M to foil pack manifold (snug fit). Do not modify the mixing nozzle. Observe the instruction for use of the dispenser.

Check foil pack holder for proper function. Do not use damaged foil packs / holders. Swing foil pack holder with foil pack into HIT-dispenser.



Discard initial adhesive. The foil pack opens automatically as dispensing is initiated. Depending on the size of the foil pack an initial amount of adhesive has to be discarded.

Discard quantities are
 2 strokes for 330 ml foil pack
 3 strokes for 500 ml foil pack

Inject adhesive from the back of the borehole without forming air voids

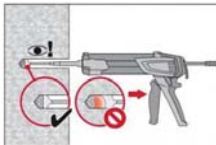

Inject the adhesive starting at the back of the hole, slowly withdrawing the mixer with each trigger pull.

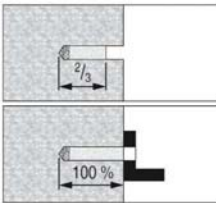

Fill holes approximately 2/3 full for Pre-setting and 100% full for through-setting, or as required to ensure that the annular gap between the anchor and the concrete is completely filled with adhesive along the embedment length.

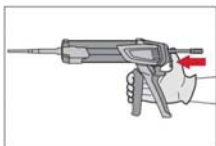

After injection is completed, depressurize the dispenser by pressing the release trigger. This will prevent further adhesive discharge from the mixer.

Overhead installation

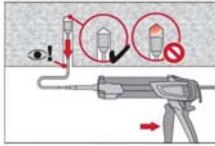

For overhead installation the injection is only possible with the aid of extensions and piston plugs. Assemble HIT-RE-M mixer, extension(s) and appropriately piston plug HIT-SZ. Insert piston plug to back of the hole and inject adhesive. During injection the piston plug will be naturally extruded out of the bore hole by the adhesive pressure

Setting the element

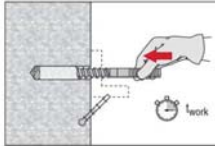

Before use, verify that the element is dry and free of oil and other contaminants. Set element to the required embedment depth until working time t_{work} has elapsed.
After setting the element the annular gap between the anchor and the fixture (through-setting) or concrete (pre-setting) has to be completely filled with mortar.

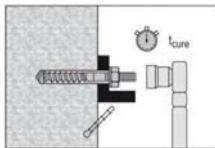

After required curing time t_{cure} remove excess mortar.
Apply indicated torque moment to activate anchor functioning principles.
The anchor can be loaded.

For detailed information on installation see instruction for use given with the package of the product.

Setting details

Anchor size			M8	M10	M12	M16	M20
Nominal diameter of drill bit	d_0	[mm]	10	12	14	18	22
Effective embedment depth range	$h_{nom,min}$	[mm]	60	60	60	96	100
	$h_{nom,max}$	[mm]	100	120	144	192	220
Minimum base material thickness	h_{min}	[mm]	$h_{nom} + 60$ mm			$h_{nom} + 100$ mm	
Pre-setting: Diameter of clearance hole in the fixture	$d_f \leq$	[mm]	9	12	14	18	22
Through-setting: Diameter of clearance hole in the fixture	$d_f \leq$	[mm]	11	14	16	20	24
Torque moment	T_{inst}	[Nm]	10	25	40	80	150

Critical edge distance and critical spacing

Critical spacing for splitting failure	$s_{cr,sp}$ [mm]	$2 c_{cr,sp}$	
Critical edge distance for splitting failure	$c_{cr,sp}$ [mm]	$1,5 \cdot h_{nom}$ for $h / h_{nom} \geq 2,35$	
		$6,2 h_{nom} - 2,0 h$ for $2,35 > h / h_{nom} > 1,35$	
		$3,5 h_{nom}$ for $h / h_{nom} \leq 1,35$	
Critical spacing for concrete cone failure	$s_{cr,N}$ [mm]	$2 c_{cr,N}$	
Critical edge distance for concrete cone failure	$c_{cr,N}$ [mm]	$1,5 h_{nom}$	

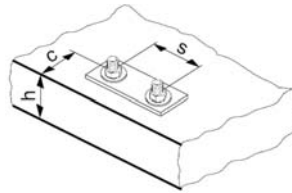

For spacing (or edge distance) smaller than critical spacing (or critical edge distance) the design loads have to be reduced.

- a) Embedment depth range: $h_{nom,min} \leq h_{nom} \leq h_{nom,max}$

Pre-setting:

Install anchor before positioning fixture

Through-setting:

Install anchor through positioned fixture

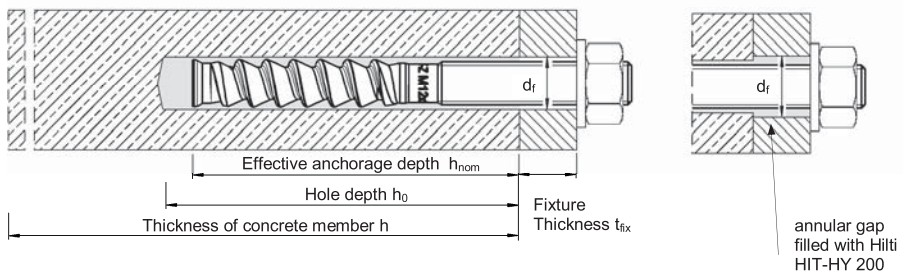

Minimum edge distance and spacing

For the calculation of minimum spacing and minimum edge distance of anchors in combination with different embedment depth and thickness of concrete member the following equation shall be fulfilled:

$$A_{i,req} < A_{i,cal}$$

Required interaction area $A_{i,req}$

Anchor size		M8	M10	M12	M16	M20
Cracked concrete	[mm ²]	19200	40800	58800	94700	148000
Uncracked concrete	[mm ²]	22200	57400	80800	128000	198000

Calculate interaction area $A_{i,cal}$

<p>Member thickness $h \geq h_{nom} + 1,5 \cdot c$</p>			
Single anchor and group of anchors with $s > 3 \cdot c$	[mm ²]	$A_{i,cal} = (6 \cdot c) \cdot (h_{nom} + 1,5 \cdot c)$	with $c \geq 5 \cdot d$
Group of anchors with $s \leq 3 \cdot c$	[mm ²]	$A_{i,cal} = (3 \cdot c + s) \cdot (h_{nom} + 1,5 \cdot c)$	with $c \geq 5 \cdot d$ and $s \geq 5 \cdot d$
<p>Member thickness $h \leq h_{nom} + 1,5 \cdot c$</p>			
Single anchor and group of anchors with $s > 3 \cdot c$	[mm ²]	$A_{i,cal} = (6 \cdot c) \cdot h$	with $c \geq 5 \cdot d$
Group of anchors with $s \leq 3 \cdot c$	[mm ²]	$A_{i,cal} = (3 \cdot c + s) \cdot h$	with $c \geq 5 \cdot d$ and $s \geq 5 \cdot d$

**Best case minimum edge distance and spacing
with required member thickness and embedment depth**

Anchor size		M8	M10	M12	M16	M20
Cracked concrete						
Member thickness	$h \geq$ [mm]	140	200	240	300	370
Embedment depth	$h_{nom} \geq$ [mm]	80	120	150	200	220
Minimum spacing	s_{min} [mm]	40	50	60	80	100
Corresponding edge distance	$c \geq$ [mm]	40	55	65	80	100
Minimum edge distance	$c_{min} =$ [mm]	40	50	60	80	100
Corresponding spacing	$s \geq$ [mm]	40	60	65	80	100
Non cracked concrete						
Member thickness	$h \geq$ [mm]	140	230	270	340	410
Embedment depth	$h_{nom} \geq$ [mm]	80	120	150	200	220
Minimum spacing	s_{min} [mm]	40	50	60	80	100
Corresponding edge distance	$c \geq$ [mm]	40	70	80	100	130
Minimum edge distance	c_{min} [mm]	40	50	60	80	100
Corresponding spacing	$s \geq$ [mm]	40	145	160	160	235

**Best case minimum member thickness and embedment depth
with required minimum edge distance and spacing**

Anchor size		M8	M10	M12	M16	M20
Cracked concrete						
Member thickness	h_{min} [mm]	120	120	120	196	200
Embedment depth	$h_{nom,min}$ [mm]	60	60	60	96	100
Minimum spacing	s_{min} [mm]	40	50	60	80	100
Corresponding edge distance	$c \geq$ [mm]	40	100	140	135	215
Minimum edge distance	$c_{min} =$ [mm]	40	60	90	80	125
Corresponding spacing	$s \geq$ [mm]	40	160	220	235	365
Non cracked concrete						
Member thickness	h_{min} [mm]	120	120	120	196	200
Embedment depth	$h_{nom,min}$ [mm]	60	60	60	96	100
Minimum spacing	s_{min} [mm]	40	50	60	80	100
Corresponding edge distance	$c \geq$ [mm]	50	145	200	190	300
Minimum edge distance	c_{min} [mm]	40	80	115	110	165
Corresponding spacing	$s \geq$ [mm]	65	240	330	310	495

Minimum edge distance and spacing – Explanation

Minimum edge and spacing geometrical requirements are determined by testing the installation conditions in which two anchors with a given spacing can be set close to an edge without forming a crack in the concrete due to tightening torque.

The HIT-Z boundary conditions for edge and spacing geometry can be found in the tables to the left. If the embedment depth and slab thickness are equal to or greater than the values in the table, then the edge and spacing values may be utilized.

PROFIS Anchor software is programmed to calculate the referenced equations in order to determine the optimized related minimum edge and spacing based on the following variables:

Cracked or uncracked concrete	For cracked concrete it is assumed that a reinforcement is present which limits the crack width to 0,3 mm, allowing smaller values for minimum edge distance and minimum spacing
Anchor diameter	For smaller anchor diameter a smaller installation torque is required, allowing smaller values for minimum edge distance and minimum spacing
Slab thickness and embedment depth	Increasing these values allows smaller values for minimum edge distance and minimum spacing

Simplified design method

Simplified version of the design method according ETAG 001, TR 029. Design resistance according data given in ETA-12/0006 (HIT-HY 200-A) and ETA-12/0028 (HIT-HY 200-R) issued on 2013-03-15

- Influence of concrete strength
- Influence of edge distance
- Influence of spacing
- Valid for a group of two anchors. (The method may also be applied for anchor groups with more than two anchors or more than one edge distance. The influencing factors must then be considered for each edge distance and spacing. The simplified calculated design loads take a conservative approach: They will be lower than the exact values according to ETAG 001, TR 029. For an optimized design, anchor calculation can be performed using PROFIS anchor design software.

The design method is based on the following simplification:

- No different loads are acting on individual anchors (no eccentricity)

The values are valid for one anchor.

For more complex fastening applications please use the anchor design software PROFIS Anchor.

TENSION loading

The design tensile resistance is the lower value of

- Steel resistance: $N_{Rd,s}$
- Combined pull-out and concrete cone resistance: $N_{Rd,p}$
- Concrete cone resistance: $N_{Rd,c} = N_{Rd,c}^0 \cdot f_B \cdot f_{1,N} \cdot f_{2,N} \cdot f_{3,N} \cdot f_{h,N} \cdot f_{re,N}$
- Concrete splitting resistance (only non-cracked concrete): $N_{Rd,sp} = N_{Rd,c}^0 \cdot f_B \cdot f_{1,sp} \cdot f_{2,sp} \cdot f_{3,sp} \cdot f_{h,N} \cdot f_{re,N}$

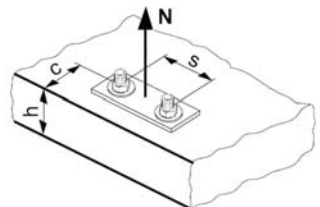

Basic design tensile resistance

Design steel resistance $N_{Rd,s}$

 $\gamma_{Ms} \geq 1.5$

Anchor size	M8	M10	M12	M16	M20
$N_{Rd,s}$ HIT-Z / HIT-Z-R [kN]	16,0	25,3	36,7	64,0	97,3

Design combined pull-out and concrete cone resistance $N_{Rd,p}^a)$

 $\gamma_{Ms} \geq 1.5$

Anchor size	M8	M10	M12	M16	M20
Non-cracked concrete					
$N_{Rd,p}^0$ Temperature range I [kN]	20,1	30,2	36,2	77,2	100,5
$N_{Rd,p}^0$ Temperature range II [kN]	18,4	27,6	33,2	70,8	92,2
$N_{Rd,p}^0$ Temperature range III [kN]	16,8	25,1	30,2	64,3	83,8
Cracked concrete					
$N_{Rd,p}^0$ Temperature range I [kN]	18,4	27,6	33,2	70,8	92,2
$N_{Rd,p}^0$ Temperature range II [kN]	16,8	25,1	30,2	64,3	83,8
$N_{Rd,p}^0$ Temperature range III [kN]	15,1	22,6	27,1	57,9	75,4

a) The combined pull-out and concrete cone resistance is independent from the embedment depth.

Design concrete cone resistance $N_{Rd,c} = N_{Rd,c}^0 \cdot f_B \cdot f_{1,N} \cdot f_{2,N} \cdot f_{3,N} \cdot f_{h,N} \cdot f_{re,N}$

Design splitting resistance $N_{Rd,sp} = N_{Rd,c}^0 \cdot f_B \cdot f_{1,sp} \cdot f_{2,sp} \cdot f_{3,sp} \cdot f_{h,N} \cdot f_{re,N}$

 $\gamma_{Ms} \geq 1.5$

Anchor size	M8	M10	M12	M16	M20
$h_{nom,typ}$ [mm]	70	90	110	145	180
$N_{Rd,c}^0$ Non cracked concrete [kN]	19,7	28,7	38,8	58,8	81,3
$N_{Rd,c}^0$ Cracked concrete [kN]	14,1	20,5	27,7	41,9	58,0

a) Splitting resistance must only be considered for non-cracked concrete.

Influencing factors

Influence of concrete strength on combined pull-out and concrete cone resistance

Concrete strength designation (ENV 206)	C 20/25	C 25/30	C 30/37	C 35/45	C 40/50	C 45/55	C 50/60
$f_{B,p} =$	1,00	1,00	1,00	1,00	1,00	1,00	1,00

Influence of concrete strength on concrete cone resistance

Concrete strength designation (ENV 206)	C 20/25	C 25/30	C 30/37	C 35/45	C 40/50	C 45/55	C 50/60
$f_B = (f_{ck,cube}/25N/mm^2)^{0,5 a)}$	1	1,1	1,22	1,34	1,41	1,48	1,55

a) $f_{ck,cube}$ = concrete compressive strength, measured on cubes with 150 mm side length

Influence of edge distance $a)$

$c/c_{cr,N}$	0,1	0,2	0,3	0,4	0,5	0,6	0,7	0,8	0,9	1
$c/c_{cr,sp}$										
$f_{1,N} = 0,7 + 0,3 \cdot c/c_{cr,N} \leq 1$	0,73	0,76	0,79	0,82	0,85	0,88	0,91	0,94	0,97	1
$f_{1,sp} = 0,7 + 0,3 \cdot c/c_{cr,sp} \leq 1$										
$f_{2,N} = 0,5 \cdot (1 + c/c_{cr,N}) \leq 1$	0,55	0,60	0,65	0,70	0,75	0,80	0,85	0,90	0,95	1
$f_{2,sp} = 0,5 \cdot (1 + c/c_{cr,sp}) \leq 1$										

a) The edge distance shall not be smaller than the minimum edge distance c_{min} . These influencing factors must be considered for every edge distance smaller than the critical edge distance.

Influence of anchor spacing ^{a)}

$s/s_{cr,N}$	0,1	0,2	0,3	0,4	0,5	0,6	0,7	0,8	0,9	1
$s/s_{cr,sp}$										
$f_{3,N} = 0,5 \cdot (1 + s/s_{cr,N}) \leq 1$										
$f_{3,sp} = 0,5 \cdot (1 + s/s_{cr,sp}) \leq 1$	0,55	0,60	0,65	0,70	0,75	0,80	0,85	0,90	0,95	1

a) The anchor spacing shall not be smaller than the minimum anchor spacing s_{min} . This influencing factor must be considered for every anchor spacing.

Influence of embedment depth on concrete cone resistance

$$f_{h,N} = (h_{nom}/h_{nom,typ})^{1.5}$$

Influence of reinforcement

h_{nom} [mm]	60	70	80	90	≥ 100
$f_{re,N} = 0,5 + h_{nom}/200mm \leq 1$	0,8 ^{a)}	0,85 ^{a)}	0,9 ^{a)}	0,95 ^{a)}	1

a) This factor applies only for dense reinforcement. If in the area of anchorage there is reinforcement with a spacing ≥ 150 mm (any diameter) or with a diameter ≤ 10 mm and a spacing ≥ 100 mm, then a factor $f_{re,N} = 1$ may be applied.

SHEAR loading

The design shear resistance is the lower value of

- Steel resistance: $V_{Rd,s}$
- Concrete pryout resistance: $V_{Rd,cp} = k \cdot \text{lower value of } N_{Rd,p} \text{ and } N_{Rd,c}$
- Concrete edge resistance: $V_{Rd,c} = V_{Rd,c}^0 \cdot f_B \cdot f_{\beta} \cdot f_h \cdot f_4 \cdot f_{hef} \cdot f_c$

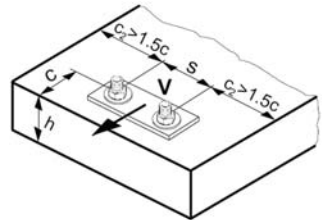

Basic design shear resistance

Design steel resistance $V_{Rd,s}$

$\gamma_{Ms} \geq 1.25$

Anchor size		M8	M10	M12	M16	M20
$V_{Rd,s}$ HIT-Z	[kN]	9,6	15,2	21,6	38,4	58,4
$V_{Rd,s}$ HIT-Z-R	[kN]	11,2	18,4	26,4	45,6	70,4

Design concrete pryout resistance $V_{Rd,cp} = \text{lower value}^a) \text{ of } k \cdot N_{Rd,p} \text{ and } k \cdot N_{Rd,c}$

$$k = 2 \text{ for } h_{ef} \geq 60 \text{ mm}$$

- a) $N_{Rd,p}$: Design combined pull-out and concrete cone resistance
 $N_{Rd,c}$: Design concrete cone resistance

Design concrete edge resistance ^{a)} $V_{Rd,c} = V_{Rd,c}^0 \cdot f_B \cdot f_{\beta} \cdot f_h \cdot f_4$

$\gamma_{Ms} \geq 1.5$

Anchor size		Non-cracked concrete					Cracked concrete				
		M8	M10	M12	M16	M20	M8	M10	M12	M16	M20
$V_{Rd,c}^0$	[kN]	5,8	8,6	11,6	18,9	27,4	4,1	6,0	8,2	13,3	19,4

a) For anchor groups only the anchors close to the edge must be considered.

Influencing factors

Influence of concrete strength

Concrete strength designation (ENV 206)	C 20/25	C 25/30	C 30/37	C 35/45	C 40/50	C 45/55	C 50/60
$f_B = (f_{ck,cube}/25N/mm^2)^{1/2}$ a)	1	1,1	1,22	1,34	1,41	1,48	1,55

a) $f_{ck,cube}$ = concrete compressive strength, measured on cubes with 150 mm side length

Influence of angle between load applied and the direction perpendicular to the free edge

Angle β	0°	10°	20°	30°	40°	50°	60°	70°	80°	≥ 90°
$f_\beta = \frac{1}{\sqrt{(\cos \alpha_v)^2 + \left(\frac{\sin \alpha_v}{2,5}\right)^2}}$	1	1,01	1,05	1,13	1,24	1,40	1,64	1,97	2,32	2,50

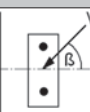

Influence of base material thickness

h/c	0,15	0,3	0,45	0,6	0,75	0,9	1,05	1,2	1,35	≥ 1,5
$f_h = \{h/(1,5 \cdot c)\}^{1/2} \leq 1$	0,32	0,45	0,55	0,63	0,71	0,77	0,84	0,89	0,95	1,00

Influence of anchor spacing and edge distance ^{a)} for concrete edge resistance: f_4

$$f_4 = (c/h_{nom})^{1,5} \cdot (1 + s / [3 \cdot c]) \cdot 0,5$$

c/h _{nom}	Single anchor	Group of two anchors s/h _{nom}															
		0,75	1,50	2,25	3,00	3,75	4,50	5,25	6,00	6,75	7,50	8,25	9,00	9,75	10,50	11,25	
0,50	0,35	0,27	0,35	0,35	0,35	0,35	0,35	0,35	0,35	0,35	0,35	0,35	0,35	0,35	0,35	0,35	0,35
0,75	0,65	0,43	0,54	0,65	0,65	0,65	0,65	0,65	0,65	0,65	0,65	0,65	0,65	0,65	0,65	0,65	0,65
1,00	1,00	0,63	0,75	0,88	1,00	1,00	1,00	1,00	1,00	1,00	1,00	1,00	1,00	1,00	1,00	1,00	1,00
1,25	1,40	0,84	0,98	1,12	1,26	1,40	1,40	1,40	1,40	1,40	1,40	1,40	1,40	1,40	1,40	1,40	1,40
1,50	1,84	1,07	1,22	1,38	1,53	1,68	1,84	1,84	1,84	1,84	1,84	1,84	1,84	1,84	1,84	1,84	1,84
1,75	2,32	1,32	1,49	1,65	1,82	1,98	2,15	2,32	2,32	2,32	2,32	2,32	2,32	2,32	2,32	2,32	2,32
2,00	2,83	1,59	1,77	1,94	2,12	2,30	2,47	2,65	2,83	2,83	2,83	2,83	2,83	2,83	2,83	2,83	2,83
2,25	3,38	1,88	2,06	2,25	2,44	2,63	2,81	3,00	3,19	3,38	3,38	3,38	3,38	3,38	3,38	3,38	3,38
2,50	3,95	2,17	2,37	2,57	2,77	2,96	3,16	3,36	3,56	3,76	3,95	3,95	3,95	3,95	3,95	3,95	3,95
2,75	4,56	2,49	2,69	2,90	3,11	3,32	3,52	3,73	3,94	4,15	4,35	4,56	4,56	4,56	4,56	4,56	4,56
3,00	5,20	2,81	3,03	3,25	3,46	3,68	3,90	4,11	4,33	4,55	4,76	4,98	5,20	5,20	5,20	5,20	5,20
3,25	5,86	3,15	3,38	3,61	3,83	4,06	4,28	4,51	4,73	4,96	5,18	5,41	5,63	5,86	5,86	5,86	5,86
3,50	6,55	3,51	3,74	3,98	4,21	4,44	4,68	4,91	5,14	5,38	5,61	5,85	6,08	6,31	6,55	6,55	6,55
3,75	7,26	3,87	4,12	4,36	4,60	4,84	5,08	5,33	5,57	5,81	6,05	6,29	6,54	6,78	7,02	7,26	7,26
4,00	8,00	4,25	4,50	4,75	5,00	5,25	5,50	5,75	6,00	6,25	6,50	6,75	7,00	7,25	7,50	7,75	7,75
4,25	8,76	4,64	4,90	5,15	5,41	5,67	5,93	6,18	6,44	6,70	6,96	7,22	7,47	7,73	7,99	8,25	8,25
4,50	9,55	5,04	5,30	5,57	5,83	6,10	6,36	6,63	6,89	7,16	7,42	7,69	7,95	8,22	8,49	8,75	8,75
4,75	10,35	5,45	5,72	5,99	6,27	6,54	6,81	7,08	7,36	7,63	7,90	8,17	8,45	8,72	8,99	9,26	9,26
5,00	11,18	5,87	6,15	6,43	6,71	6,99	7,27	7,55	7,83	8,11	8,39	8,66	8,94	9,22	9,50	9,78	9,78
5,25	12,03	6,30	6,59	6,87	7,16	7,45	7,73	8,02	8,31	8,59	8,88	9,17	9,45	9,74	10,02	10,31	10,31
5,50	12,90	6,74	7,04	7,33	7,62	7,92	8,21	8,50	8,79	9,09	9,38	9,67	9,97	10,26	10,55	10,85	10,85

a) The anchor spacing and the edge distance shall not be smaller than the minimum anchor spacing s_{min} and the minimum edge distance c_{min} .

Influence of embedment depth

h_{nom}/d	4	4,5	5	6	7	8	9	10	11
$f_{hef} = 0,05 \cdot (h_{nom} / d)^{1,68}$	0,51	0,63	0,75	1,01	1,31	1,64	2,00	2,39	2,81
h_{ef}/d	12	13	14	15	16	17	18	19	20
$f_{hef} = 0,05 \cdot (h_{nom} / d)^{1,68}$	3,25	3,72	4,21	4,73	5,27	5,84	6,42	7,04	7,67

Influence of edge distance ^{a)}





c/d	4	6	8	10	15	20	30	40
$f_c = (d / c)^{0,19}$	0,77	0,71	0,67	0,65	0,60	0,57	0,52	0,50

a) The edge distance shall not be smaller than the minimum edge distance c_{min} .

Combined TENSION and SHEAR loading

For combined tension and shear loading see section "Anchor Design".

Hilti HIT-HY 200 with HIT-V

Injection mortar system	Benefits
 <p>Hilti HIT-HY 200-A 500 ml foil pack (also available as 330 ml foil pack)</p>	<ul style="list-style-type: none"> - Suitable for non-cracked and cracked concrete C 20/25 to C 50/60
 <p>Hilti HIT-HY 200-R 500 ml foil pack (also available as 330 ml foil pack)</p>	<ul style="list-style-type: none"> - Suitable for dry and water saturated concrete - High loading capacity, excellent handling and fast curing - Small edge distance and anchor spacing possible
 <p>Static mixer</p>	<ul style="list-style-type: none"> - Large diameter applications - Max In service temperature range up to 120°C short term/ 72°C long term
 <p>HIT-V rods HIT-V-R rods HIT-V-HCR rods</p>	<ul style="list-style-type: none"> - Manual cleaning for borehole diameter up to 20mm and $h_{ef} \geq 10d$ for non-cracked concrete only - Embedment depth range: from 60 ... 160 mm for M8 to 120 ... 600 mm for M30 - Two mortar (A and R) versions available with different curing times and same performance



Concrete



Tensile zone



Small edge distance and spacing



Variable embedment depth



Corrosion resistance



High corrosion resistance



European Technical Approval



CE conformity



PROFIS Anchor design software

Approvals / certificates

Description	Authority / Laboratory	No. / date of issue
European technical approval ^{a)}	DIBt, Berlin	ETA-11/0493 / 2012-08-08 (Hilti HIT-HY 200-A) ETA-12/0084 / 2012-08-08 (Hilti HIT-HY 200-R)
Fire test report	IBMB, Brunswick	3501/676/13 / 2012-08-03

a) All data given in this section according ETA-11/0493 and ETA-12/0084, issue 2012-08-08.

Basic loading data (for a single anchor)

All data in this section applies to

- Correct setting (See setting instruction)
- No edge distance and spacing influence
- Steel failure
- Base material thickness, as specified in the table
- One typical embedment depth, as specified in the table
- One anchor material, as specified in the tables
- Concrete C 20/25, $f_{ck,cube} = 25 \text{ N/mm}^2$
- Temperature range I
(min. base material temperature -40°C , max. long term/short term base material temperature: $+24^\circ\text{C}/40^\circ\text{C}$)
- Installation temperature range -10°C to $+40^\circ\text{C}$

For details see Simplified design method

Embedment depth ^{a)} and base material thickness for the basic loading data. Mean ultimate resistance, characteristic resistance, design resistance, recommended loads.

Anchor size	M8	M10	M12	M16	M20	M24	M27	M30
Typical embedment depth h_{ef} [mm]	80	90	110	125	170	210	240	270
Base material thickness h [mm]	110	120	140	165	220	270	300	340

a) The allowed range of embedment depth is shown in the setting details. The corresponding load values can be calculated according to the simplified design method.

Characteristic resistance: concrete C 20/25 , anchor HIT-V 5.8 / HIT-VR A4

Anchor size	M8	M10	M12	M16	M20	M24	M27	M30
Non-cracked concrete								
Tensile N_{Rk} HIT-V 5.8 [kN]	18,0	29,0	42,0	70,6	111,9	153,7	187,8	224,0
Shear V_{Rk} HIT-V 5.8 [kN]	9,0	15,0	21,0	39,0	61,0	88,0	115,0	140,0
Tensile N_{Rk} HIT-VR A4 [kN]	26,0	41,0	58,3	70,6	111,9	153,7	187,8	224,0
Shear V_{Rk} HIT-VR A4 [kN]	13,0	20,0	30,0	55,0	86,0	124,0	115,0	140,0
Cracked concrete								
Tensile N_{Rk} HIT-V 5.8 [kN]	12,1	17,0	33,2	50,3	79,8	109,6	133,9	159,7
Shear V_{Rk} HIT-V 5.8 [kN]	9,0	15,0	21,0	39,0	61,0	88,0	115,0	140,0
Tensile N_{Rk} HIT-VR A4 [kN]	12,1	17,0	33,2	50,3	79,8	109,6	133,9	159,7
Shear V_{Rk} HIT-VR A4 [kN]	13,0	20,0	30,0	55,0	86,0	124,0	115,0	140,0

Design resistance: concrete C 20/25 , anchor HIT-V 5.8 / HIT-VR A4

Anchor size	M8	M10	M12	M16	M20	M24	M27	M30
Non-cracked concrete								
Tensile N_{Rd} HIT-V 5.8 [kN]	12,0	19,3	28,0	39,2	62,2	85,4	104,3	124,5
Shear V_{Rd} HIT-V 5.8 [kN]	7,2	12,0	16,8	31,2	48,8	70,4	92,0	112,0
Tensile N_{Rk} HIT-VR A4 [kN]	13,9	21,9	32,4	33,6	53,3	73,2	89,4	106,7
Shear V_{Rk} HIT-VR A4 [kN]	8,30	12,80	19,2	35,2	55,1	79,4	48,3	58,8
Cracked concrete								
Tensile N_{Rd} HIT-V 5.8 [kN]	6,7	9,4	18,4	27,9	44,3	60,9	74,4	88,7
Shear V_{Rd} HIT-V 5.8 [kN]	7,2	12,0	16,8	31,2	48,8	70,4	92,0	112,0
Tensile N_{Rk} HIT-VR A4 [kN]	8,9	12,6	17,3	20,9	35,6	52,2	63,0	72,7
Shear V_{Rk} HIT-VR A4 [kN]	8,30	12,80	19,2	35,2	55,1	79,4	48,3	58,8

Recommended loads ^{a)}: concrete C 20/25 , anchor HIT-V 5.8 / HIT-VR A4

Anchor size			M8	M10	M12	M16	M20	M24	M27	M30
Non-cracked concrete										
Tensile N _{rec}	HIT-V 5.8	[kN]	6,0	9,7	14,0	23,5	37,3	51,2	62,6	74,7
Shear V _{rec}	HIT-V 5.8	[kN]	3,0	5,0	7,0	13,0	20,3	29,3	38,3	46,7
Tensile N _{rec}	HIT-VR A4	[kN]	8,6	13,6	19,4	23,5	37,3	51,2	62,6	74,7
Shear V _{rec}	HIT-VR A4	[kN]	4,3	6,6	10,0	18,3	28,6	41,3	38,3	46,4
Cracked concrete										
Tensile N _{rec}	HIT-V 5.8	[kN]	4,0	5,7	11,1	16,8	26,6	36,5	44,6	53,2
Shear V _{rec}	HIT-V 5.8	[kN]	3,0	5,0	7,0	13,0	20,3	29,3	38,3	46,7
Tensile N _{rec}	HIT-VR A4	[kN]	4,0	5,7	11,1	16,8	26,6	36,5	44,6	53,2
Shear V _{rec}	HIT-VR A4	[kN]	4,3	6,6	10,0	18,3	28,6	41,3	38,3	46,4

a) With overall global safety factor $\gamma = 3,0$. The recommended loads vary according to the safety factor requirement from national regulations.

Service temperature range

Hilti HIT-HY 200 injection mortar may be applied in the temperature ranges given below. An elevated base material temperature may lead to a reduction of the design bond resistance.

Temperature range	Base material temperature	Maximum long term base material temperature	Maximum short term base material temperature
Temperature range I	-40°C to +40°C	+24°C	+40°C
Temperature range II	-40°C to +80°C	+50°C	+80°C
Temperature range III	-40°C to +120°C	+72°C	+120°C

Max short term base material temperature

Short-term elevated base material temperatures are those that occur over brief intervals, e.g. as a result of diurnal cycling.

Max long term base material temperature

Long-term elevated base material temperatures are roughly constant over significant periods of time.

Materials

Mechanical properties of HIT-V

Anchor size			M8	M10	M12	M16	M20	M24	M27	M30
Nominal tensile strength f _{tk}	HIT-V 5.8	[N/mm ²]	500	500	500	500	500	500	500	500
	HIT-V 8.8	[N/mm ²]	800	800	800	800	800	800	800	800
	HIT-V-R	[N/mm ²]	700	700	700	700	700	700	500	500
	HIT-V-HCR	[N/mm ²]	800	800	800	800	800	700	700	700
Yield strength f _{yk}	HIT-V 5.8	[N/mm ²]	400	400	400	400	400	400	400	400
	HIT-V 8.8	[N/mm ²]	640	640	640	640	640	640	640	640
	HIT-V -R	[N/mm ²]	450	450	450	450	450	450	210	210
	HIT-V-HCR	[N/mm ²]	640	640	640	640	640	400	400	400
Stressed cross-section A _s	HIT-V	[mm ²]	36,6	58,0	84,3	157	245	353	459	561
Moment of resistance W	HIT-V	[mm ³]	31,2	62,3	109	277	541	935	1387	1874

Material quality

Part	Material
Threaded rod HIT-V(F)	Strength class 5.8, $A_5 > 8\%$ ductile steel galvanized $\geq 5 \mu\text{m}$, (F) hot dipped galvanized $\geq 45 \mu\text{m}$,
Threaded rod HIT-V(F)	Strength class 8.8, $A_5 > 8\%$ ductile steel galvanized $\geq 5 \mu\text{m}$, (F) hot dipped galvanized $\geq 45 \mu\text{m}$,
Threaded rod HIT-V-R	Stainless steel grade A4, $A_5 > 8\%$ ductile strength class 70 for $\leq M24$ and class 50 for M27 to M30, 1.4401; 1.4404; 1.4578; 1.4571; 1.4439; 1.4362
Threaded rod HIT-V-HCR	High corrosion resistant steel, 1.4529; 1.4565 strength $\leq M20$: $R_m = 800 \text{ N/mm}^2$, $R_{p0.2} = 640 \text{ N/mm}^2$, $A_5 > 8\%$ ductile M24 to M30: $R_m = 700 \text{ N/mm}^2$, $R_{p0.2} = 400 \text{ N/mm}^2$, $A_5 > 8\%$ ductile
Washer ISO 7089	Steel galvanized, hot dipped galvanized,
	Stainless steel, 1.4401; 1.4404; 1.4578; 1.4571; 1.4439; 1.4362
Nut EN ISO 4032	High corrosion resistant steel, 1.4529; 1.4565
	Strength class 8, steel galvanized $\geq 5 \mu\text{m}$, hot dipped galvanized $\geq 45 \mu\text{m}$,
	Strength class 70, stainless steel grade A4, 1.4401; 1.4404; 1.4578; 1.4571; 1.4439; 1.4362
	Strength class 70, high corrosion resistant steel, 1.4529; 1.4565

Anchor dimensions

Anchor size	M8	M10	M12	M16	M20	M24	M27	M30
Anchor rod HIT-V, HIT-V-R, HIT-V-HCR	Anchor rods HIT-V (-R / -HCR) are available in variable length							

Setting

Installation equipment

Anchor size	M8	M10	M12	M16	M20	M24	M27	M30
Rotary hammer	TE 2 – TE 16				TE 40 – TE 70			
Other tools, hammer drilling	compressed air gun or blow out pump, set of cleaning brushes, dispenser							

Setting instruction

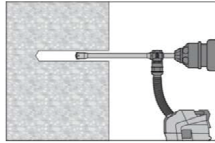
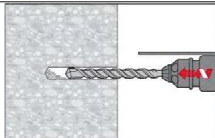
Bore hole drilling	
	Drill hole to the required embedment depth with an appropriately sized Hilti TE-CD or TE-YD hollow drill bit with Hilti vacuum attachment. This drilling method properly cleans the borehole and removes dust while drilling. After drilling is complete, proceed to the "injection preparation" step in the instructions for use.
	Drill Hole to the required embedment depth with a hammer drill set in rotation-hammer mode using an appropriately sized carbide drill bit.

Injection preparation

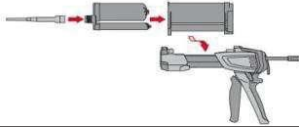

Tightly attach new Hilti mixing nozzle HIT-RE-M to foil pack manifold (snug fit). Do not modify the mixing nozzle. Observe the instruction for use of the dispenser. Check foil pack holder for proper function. Do not use damaged foil packs / holders. Swing foil pack holder with foil pack into HIT-dispenser.



Discard initial adhesive. The foil pack opens automatically as dispensing is initiated. Depending on the size of the foil pack an initial amount of adhesive has to be discarded.

Discard quantities are:

2 strokes for 330 ml foil pack,

3 strokes for 500 ml foil pack,

4 strokes for 500 ml foil pack $\leq 5^{\circ}\text{C}$.

Inject adhesive from the back of the borehole without forming air voids

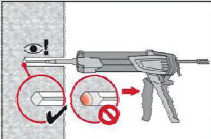

Inject the adhesive starting at the back of the hole, slowly withdrawing the mixer with each trigger pull. Fill holes approximately 2/3 full, or as required to ensure that the annular gap between the anchor and the concrete is completely filled with adhesive along the embedment length.

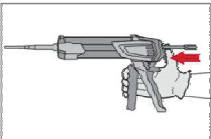

After injection is completed, depressurize the dispenser by pressing the release trigger. This will prevent further adhesive discharge from the mixer.

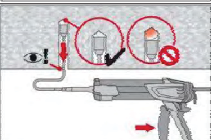

Overhead installation and/or installation with embedment depth $h_{\text{eff}} > 250\text{mm}$. For overhead installation the injection is only possible with the aid of extensions and piston plugs. Assemble HIT-RE-M mixer, extension(s) and appropriately sized piston plug. Insert piston plug to back of the hole and inject adhesive. During injection the piston plug will be naturally extruded out of the bore hole by the adhesive pressure.

Setting the element

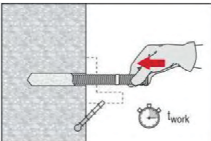

Before use, verify that the element is dry and free of oil and other contaminants. Mark and set element to the required embedment depth until working time t_{work} has elapsed.

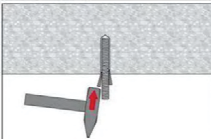

For overhead installation use piston plugs and fix embedded parts with e.g. wedges

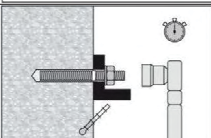

Loading the anchor:

After required curing time t_{cure} the anchor can be loaded.

The applied installation torque shall not exceed T_{max} .

For detailed information on installation see instruction for use given with the package of the product.

Bore hole cleaning Just before setting an anchor, the bore hole must be free of dust and debris.

a) Manual Cleaning (MC) non-cracked concrete only

for bore hole diameters $d_0 \leq 20\text{mm}$ and bore hole depth $h_0 \leq 10d$

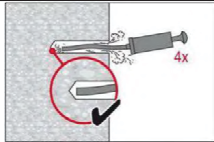

The Hilti manual pump may be used for blowing out bore holes up to diameters $d_0 \leq 20\text{ mm}$ and embedment depths up to $h_{ef} \leq 10d$. Blow out at least 4 times from the back of the bore hole until return air stream is free of noticeable dust

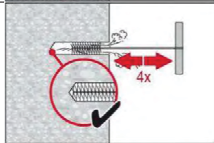

Brush 4 times with the specified brush size by inserting the steel brush Hilti HIT-RB to the back of the hole (if needed with extension) in a twisting motion and removing it. The brush must produce natural resistance as it enters the bore hole -- if not the brush is too small and must be replaced with the proper brush diameter.

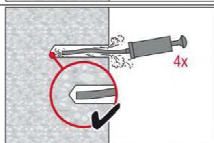

Blow out again with manual pump at least 4 times until return air stream is free of noticeable dust.

b) Compressed air cleaning (CAC)

for all bore hole diameters d_0 and all bore hole depth h_0

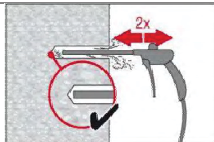

Blow 2 times from the back of the hole (if needed with nozzle extension) over the hole length with oil-free compressed air (min. 6 bar at 6 m³/h) until return air stream is free of noticeable dust. Bore hole diameter $\geq 32\text{ mm}$ the compressor must supply a minimum air flow of 140 m³/hour.

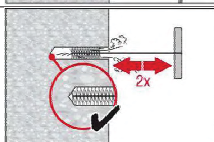

Brush 2 times with the specified brush size by inserting the steel brush Hilti HIT-RB to the back of the hole (if needed with extension) in a twisting motion and removing it. The brush must produce natural resistance as it enters the bore hole -- if not the brush is too small and must be replaced with the proper brush diameter.

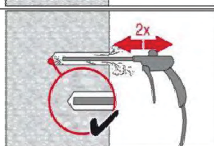

Blow again with compressed air 2 times until return air stream is free of noticeable dust.

Working time, curing time

Temperature of the base material	Hilti HIT-HY 200-R	
	Working time in which anchor can be inserted and adjusted t_{work}	Curing time before anchor can be loaded t_{cure}
-10°C to -5°C	3 hour	20 hour
-4°C to 0°C	2 hour	7 hour
1°C to 5°C	1 hour	3 hour
6°C to 10°C	40 min	2 hour
11°C to 20°C	15 min	1 hour
21°C to 30°C	9 min	1 hour
31°C to 40°C	6 min	1 hour

Temperature of the base material	Hilti HIT-HY 200-A	
	Working time in which anchor can be inserted and adjusted t_{work}	Curing time before anchor can be loaded t_{cure}
-10°C to -5°C	1,5 hour	7 hour
-4°C to 0°C	50 min	4 hour
1°C to 5°C	25 min	2 hour
6°C to 10°C	15 min	1 hour
11°C to 20°C	7 min	30 min
21°C to 30°C	4 min	30 min
31°C to 40°C	3 min	30 min

Setting details

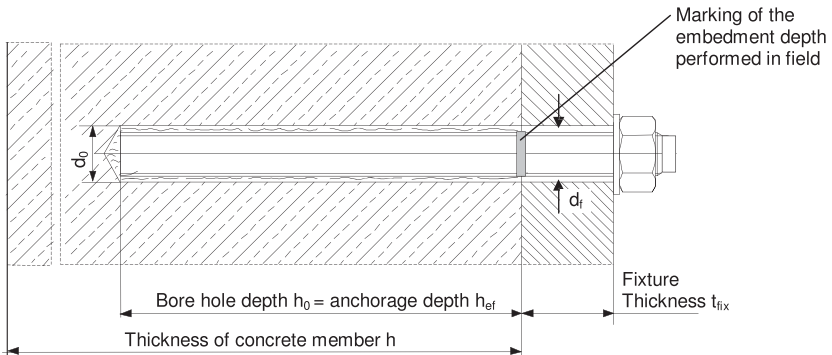

Setting details

Anchor size		M8	M10	M12	M16	M20	M24	M27	M30
Nominal diameter of drill bit	d_0 [mm]	10	12	14	18	22	28	30	35
Effective embedment and drill hole depth range ^{a)} for HIT-V	$h_{ef,min}$ [mm]	60	60	70	80	90	96	108	120
	$h_{ef,max}$ [mm]	160	200	240	320	400	480	540	600
Minimum base material thickness	h_{min} [mm]	$h_{ef} + 30$ mm			$h_{ef} + 2 d_0$				
Diameter of clearance hole in the fixture	d_f [mm]	9	12	14	18	22	26	30	33
Torque moment	$T_{max}^{b)}$ [Nm]	10	20	40	80	150	200	270	300
Minimum spacing	s_{min} [mm]	40	50	60	80	100	120	135	150
Minimum edge distance	c_{min} [mm]	40	50	60	80	100	120	135	150
Critical spacing for splitting failure	$s_{cr,sp}$ [mm]	$2 C_{cr,sp}$							
Critical edge distance for splitting failure ^{c)}	$c_{cr,sp}$ [mm]	$1,0 \cdot h_{ef}$ for $h / h_{ef} \geq 2,0$							
		$4,6 h_{ef} - 1,8 h$ for $2,0 > h / h_{ef} > 1,3$							
		$2,26 h_{ef}$ for $h / h_{ef} \leq 1,3$							
Critical spacing for concrete cone failure	$s_{cr,N}$ [mm]	$2 C_{cr,N}$							
Critical edge distance for concrete cone failure ^{d)}	$c_{cr,N}$ [mm]	$1,5 h_{ef}$							

For spacing (or edge distance) smaller than critical spacing (or critical edge distance) the design loads have to be reduced.

- a) Embedment depth range: $h_{ef,min} \leq h_{ef} \leq h_{ef,max}$
- b) Maximum recommended torque moment to avoid splitting failure during installation with minimum spacing and/or edge distance.
- c) h : base material thickness ($h \geq h_{min}$), h_{ef} : embedment depth
- d) The critical edge distance for concrete cone failure depends on the embedment depth h_{ef} and the design bond resistance. The simplified formula given in this table is on the safe side.

Simplified design method

Simplified version of the design method according ETAG 001, TR 029. Design resistance according data given in ETA-11/0493 issued 2012-08-08 for HIT-HY 200-A and ETA-12/0084 issued 2012-08-08 for HIT-HY 200-R. Both mortars possess identical technical load performance.

- Influence of concrete strength
- Influence of edge distance
- Influence of spacing
- Valid for a group of two anchors. (The method may also be applied for anchor groups with more than two anchors or more than one edge distance. The influencing factors must then be considered for each edge distance and spacing. The simplified calculated design loads take a conservative approach: They will be lower than the exact values according to ETAG 001, TR 029. For an optimized design, anchor calculation can be performed using PROFIS anchor design software.

The design method is based on the following simplification:

- No different loads are acting on individual anchors (no eccentricity)

The values are valid for one anchor.

For more complex fastening applications please use the anchor design software PROFIS Anchor.

TENSION loading

The design tensile resistance is the lower value of

- Steel resistance:

$$N_{Rd,s}$$

- Combined pull-out and concrete cone resistance:

$$N_{Rd,p} = N_{Rd,p}^0 \cdot f_{B,p} \cdot f_{1,N} \cdot f_{2,N} \cdot f_{3,N} \cdot f_{h,p} \cdot f_{re,N}$$

- Concrete cone resistance: $N_{Rd,c} = N_{Rd,c}^0 \cdot f_B \cdot f_{1,N} \cdot f_{2,N} \cdot f_{3,N} \cdot f_{h,N} \cdot f_{re,N}$

- Concrete splitting resistance (only non-cracked concrete):

$$N_{Rd,sp} = N_{Rd,c}^0 \cdot f_B \cdot f_{1,sp} \cdot f_{2,sp} \cdot f_{3,sp} \cdot f_{h,N} \cdot f_{re,N}$$

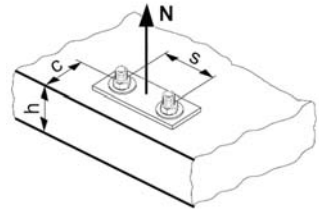

Basic design tensile resistance

Design steel resistance $N_{Rd,s}$

$\gamma_{Ms} \geq 1.5$

Anchor size		M8	M10	M12	M16	M20	M24	M27	M30
$N_{Rd,s}$	HIT-V 5.8 [kN]	12,0	19,3	28,0	52,7	82,0	118,0	153,3	187,3
	HIT-V 8.8 [kN]	19,3	30,7	44,7	84,0	130,7	188,0	244,7	299,3
	HIT-V-R [kN]	13,9	21,9	31,6	58,8	92,0	132,1	80,4	98,3
	HIT-V-HCR [kN]	19,3	30,7	44,7	84,0	130,7	117,6	152,9	187,1

Design combined pull-out and concrete cone resistance

$$N_{Rd,p} = N_{Rd,p}^0 \cdot f_{B,p} \cdot f_{1,N} \cdot f_{2,N} \cdot f_{3,N} \cdot f_{h,p} \cdot f_{re,N}$$

$\gamma_{Ms} \geq 1.5$

Anchor size	M8	M10	M12	M16	M20	M24	M27	M30
Typical embedment depth $h_{ef} = h_{ef,typ}$ [mm]	80	90	110	125	170	210	240	270
Non-cracked concrete								
$N_{Rd,p}^0$ Temperature range I [kN]	22,3	31,4	46,1	69,8	118,7	175,9	169,6	212,1
$N_{Rd,p}^0$ Temperature range II [kN]	19,0	26,7	39,2	59,3	100,9	149,5	135,7	169,6
$N_{Rd,p}^0$ Temperature range III [kN]	15,6	22,0	32,3	48,9	83,1	123,2	124,4	155,5
Cracked concrete								
$N_{Rd,p}^0$ Temperature range I [kN]	6,7	9,4	18,4	27,9	47,5	70,4	90,5	113,1
$N_{Rd,p}^0$ Temperature range II [kN]	5,0	7,1	15,0	22,7	38,6	57,2	73,5	91,9
$N_{Rd,p}^0$ Temperature range III [kN]	4,5	6,3	12,7	19,2	32,6	48,4	62,2	77,8

$$\text{Design concrete cone resistance } N_{Rd,c} = N_{Rd,c}^0 \cdot f_B \cdot f_{1,N} \cdot f_{2,N} \cdot f_{3,N} \cdot f_{h,N} \cdot f_{re,N}$$

$$\text{Design splitting resistance } N_{Rd,sp} = N_{Rd,sp}^0 \cdot f_B \cdot f_{1,sp} \cdot f_{2,sp} \cdot f_{3,sp} \cdot f_{h,N} \cdot f_{re,N}$$

$\gamma_{Ms} \geq 1.5$

Anchor size	M8	M10	M12	M16	M20	M24	M27	M30
$N_{Rd,c}^0$ Non-cracked concrete [kN]	20,1	24,0	32,4	39,2	62,2	85,4	104,3	124,5
$N_{Rd,c}^0$ Cracked concrete [kN]	14,3	17,1	23,1	28,0	44,3	60,9	74,4	88,7

a) Splitting resistance must only be considered for non-cracked concrete.

Influencing factors

Influence of concrete strength on combined pull-out and concrete cone resistance

Concrete strength designation (ENV 206)	C 20/25	C 25/30	C 30/37	C 35/45	C 40/50	C 45/55	C 50/60
$f_{B,p} =$	1,00	1,00	1,00	1,00	1,00	1,00	1,00

Influence of embedment depth on combined pull-out and concrete cone resistance

$f_{h,p} = h_{ef}/h_{ef,typ}$

Influence of concrete strength on concrete cone resistance

Concrete strength designation (ENV 206)	C 20/25	C 25/30	C 30/37	C 35/45	C 40/50	C 45/55	C 50/60
$f_B = (f_{ck,cube}/25N/mm^2)^{0,5 a)}$	1	1,1	1,22	1,34	1,41	1,48	1,55

a) $f_{ck,cube}$ = concrete compressive strength, measured on cubes with 150 mm side length

Influence of edge distance ^{a)}

$c/c_{cr,N}$	0,1	0,2	0,3	0,4	0,5	0,6	0,7	0,8	0,9	1
$c/c_{cr,sp}$										
$f_{1,N} = 0,7 + 0,3 \cdot c/c_{cr,N} \leq 1$	0,73	0,76	0,79	0,82	0,85	0,88	0,91	0,94	0,97	1
$f_{1,sp} = 0,7 + 0,3 \cdot c/c_{cr,sp} \leq 1$										
$f_{2,N} = 0,5 \cdot (1 + c/c_{cr,N}) \leq 1$	0,55	0,60	0,65	0,70	0,75	0,80	0,85	0,90	0,95	1
$f_{2,sp} = 0,5 \cdot (1 + c/c_{cr,sp}) \leq 1$										

a) The edge distance shall not be smaller than the minimum edge distance c_{min} . These influencing factors must be considered for every edge distance smaller than the critical edge distance.

Influence of anchor spacing ^{a)}

$s/s_{cr,N}$	0,1	0,2	0,3	0,4	0,5	0,6	0,7	0,8	0,9	1
$s/s_{cr,sp}$										
$f_{3,N} = 0,5 \cdot (1 + s/s_{cr,N}) \delta 1$										
$f_{3,sp} = 0,5 \cdot (1 + s/s_{cr,sp}) \delta 1$	0,55	0,60	0,65	0,70	0,75	0,80	0,85	0,90	0,95	1

a) The anchor spacing shall not be smaller than the minimum anchor spacing s_{min} . This influencing factor must be considered for every anchor spacing.

Influence of embedment depth on concrete cone resistance

$$f_{h,N} = (h_{ef}/h_{ef,typ})^{1,5}$$

Influence of reinforcement

h_{ef} [mm]	60	70	80	90	≥ 100
$f_{re,N} = 0,5 + h_{ef}/200\text{mm} \leq 1$	0,8 ^{a)}	0,85 ^{a)}	0,9 ^{a)}	0,95 ^{a)}	1

a) This factor applies only for dense reinforcement. If in the area of anchorage there is reinforcement with a spacing ≥ 150 mm (any diameter) or with a diameter ≤ 10 mm and a spacing ≥ 100 mm, then a factor $f_{re,N} = 1$ may be applied.

SHEAR loading

The design shear resistance is the lower value of

- Steel resistance: $V_{Rd,s}$
- Concrete pryout resistance: $V_{Rd,cp} = k \cdot \text{lower value of } N_{Rd,p} \text{ and } N_{Rd,c}$
- Concrete edge resistance: $V_{Rd,c} = V_{Rd,c}^0 \cdot f_B \cdot f_{\beta} \cdot f_h \cdot f_4 \cdot f_{hef} \cdot f_c$

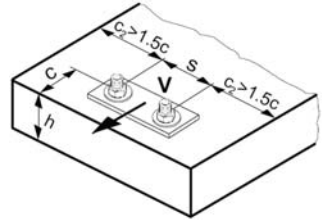

Basic design shear resistance

Design steel resistance $V_{Rd,s}$

$\gamma_{Ms} \geq 1,25$

Anchor size	M8	M10	M12	M16	M20	M24	M27	M30
HIT-V 5.8 [kN]	7,2	12,0	16,8	31,2	48,8	70,4	92,0	112,0
HIT-V 8.8 [kN]	12,0	18,4	27,2	50,4	78,4	112,8	147,2	179,2
HIT-V-R [kN]	8,3	12,8	19,2	35,3	55,1	79,5	48,3	58,8
HIT-V-HCR [kN]	12,0	18,4	27,2	50,4	78,4	70,9	92,0	110,3

Design concrete pryout resistance $V_{Rd,cp} = \text{lower value}^a)$ of $k \cdot N_{Rd,p}$ and $k \cdot N_{Rd,c}$

$$k = 2$$

a) $N_{Rd,p}$: Design combined pull-out and concrete cone resistance, $N_{Rd,c}$: Design concrete cone resistance

Design concrete edge resistance $V_{Rd,c} = V_{Rd,c}^0 \cdot f_B \cdot f_{\beta} \cdot f_h \cdot f_4 \cdot f_{hef} \cdot f_c$

$\gamma_{Ms} \geq 1,5$

Anchor size	M8	M10	M12	M16	M20	M24	M27	M30
Non-cracked concrete								
$V_{Rd,c}^0$ [kN]	5,9	8,6	11,6	18,7	27,0	36,6	44,5	53,0
Cracked concrete								
$V_{Rd,c}^0$ [kN]	4,2	6,1	8,2	13,2	19,2	25,9	31,5	37,5

Influencing factors

Influence of concrete strength

Concrete strength designation (ENV 206)	C 20/25	C 25/30	C 30/37	C 35/45	C 40/50	C 45/55	C 50/60
$f_B = (f_{ck,cube}/25\text{N/mm}^2)^{1/2 \text{ a)}$	1	1,1	1,22	1,34	1,41	1,48	1,55

a) $f_{ck,cube}$ = concrete compressive strength, measured on cubes with 150 mm side length

Influence of angle between load applied and the direction perpendicular to the free edge

Angle β	0°	10°	20°	30°	40°	50°	60°	70°	80°	≥ 90°
$f_\beta = \frac{1}{\sqrt{(\cos \alpha_v)^2 + \left(\frac{\sin \alpha_v}{2,5}\right)^2}}$	1	1,01	1,05	1,13	1,24	1,40	1,64	1,97	2,32	2,50

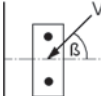

Influence of base material thickness

h/c	0,15	0,3	0,45	0,6	0,75	0,9	1,05	1,2	1,35	≥ 1,5
$f_h = \{h/(1,5 \cdot c)\}^{1/2} \leq 1$	0,32	0,45	0,55	0,63	0,71	0,77	0,84	0,89	0,95	1,00

Influence of anchor spacing and edge distance ^{a)} for concrete edge resistance: f_4

$$f_4 = (c/h_{ef})^{1,5} \cdot (1 + s / [3 \cdot c]) \cdot 0,5$$

c/h _{ef}	Single anchor	Group of two anchors s/h _{ef}															
		0,75	1,50	2,25	3,00	3,75	4,50	5,25	6,00	6,75	7,50	8,25	9,00	9,75	10,50	11,25	
0,50	0,35	0,27	0,35	0,35	0,35	0,35	0,35	0,35	0,35	0,35	0,35	0,35	0,35	0,35	0,35	0,35	0,35
0,75	0,65	0,43	0,54	0,65	0,65	0,65	0,65	0,65	0,65	0,65	0,65	0,65	0,65	0,65	0,65	0,65	0,65
1,00	1,00	0,63	0,75	0,88	1,00	1,00	1,00	1,00	1,00	1,00	1,00	1,00	1,00	1,00	1,00	1,00	1,00
1,25	1,40	0,84	0,98	1,12	1,26	1,40	1,40	1,40	1,40	1,40	1,40	1,40	1,40	1,40	1,40	1,40	1,40
1,50	1,84	1,07	1,22	1,38	1,53	1,68	1,84	1,84	1,84	1,84	1,84	1,84	1,84	1,84	1,84	1,84	1,84
1,75	2,32	1,32	1,49	1,65	1,82	1,98	2,15	2,32	2,32	2,32	2,32	2,32	2,32	2,32	2,32	2,32	2,32
2,00	2,83	1,59	1,77	1,94	2,12	2,30	2,47	2,65	2,83	2,83	2,83	2,83	2,83	2,83	2,83	2,83	2,83
2,25	3,38	1,88	2,06	2,25	2,44	2,63	2,81	3,00	3,19	3,38	3,38	3,38	3,38	3,38	3,38	3,38	3,38
2,50	3,95	2,17	2,37	2,57	2,77	2,96	3,16	3,36	3,56	3,76	3,95	3,95	3,95	3,95	3,95	3,95	3,95
2,75	4,56	2,49	2,69	2,90	3,11	3,32	3,52	3,73	3,94	4,15	4,35	4,56	4,56	4,56	4,56	4,56	4,56
3,00	5,20	2,81	3,03	3,25	3,46	3,68	3,90	4,11	4,33	4,55	4,76	4,98	5,20	5,20	5,20	5,20	5,20
3,25	5,86	3,15	3,38	3,61	3,83	4,06	4,28	4,51	4,73	4,96	5,18	5,41	5,63	5,86	5,86	5,86	5,86
3,50	6,55	3,51	3,74	3,98	4,21	4,44	4,68	4,91	5,14	5,38	5,61	5,85	6,08	6,31	6,55	6,55	6,55
3,75	7,26	3,87	4,12	4,36	4,60	4,84	5,08	5,33	5,57	5,81	6,05	6,29	6,54	6,78	7,02	7,26	7,26
4,00	8,00	4,25	4,50	4,75	5,00	5,25	5,50	5,75	6,00	6,25	6,50	6,75	7,00	7,25	7,50	7,75	7,75
4,25	8,76	4,64	4,90	5,15	5,41	5,67	5,93	6,18	6,44	6,70	6,96	7,22	7,47	7,73	7,99	8,25	8,25
4,50	9,55	5,04	5,30	5,57	5,83	6,10	6,36	6,63	6,89	7,16	7,42	7,69	7,95	8,22	8,49	8,75	8,75
4,75	10,35	5,45	5,72	5,99	6,27	6,54	6,81	7,08	7,36	7,63	7,90	8,17	8,45	8,72	8,99	9,26	9,26
5,00	11,18	5,87	6,15	6,43	6,71	6,99	7,27	7,55	7,83	8,11	8,39	8,66	8,94	9,22	9,50	9,78	9,78
5,25	12,03	6,30	6,59	6,87	7,16	7,45	7,73	8,02	8,31	8,59	8,88	9,17	9,45	9,74	10,02	10,31	10,31
5,50	12,90	6,74	7,04	7,33	7,62	7,92	8,21	8,50	8,79	9,09	9,38	9,67	9,97	10,26	10,55	10,85	10,85

a) The anchor spacing and the edge distance shall not be smaller than the minimum anchor spacing s_{min} and the minimum edge distance c_{min} .

Influence of embedment depth

h_{ef}/d	4	4,5	5	6	7	8	9	10	11
$f_{hef} = 0,05 \oplus (h_{ef} / d)^{68}$	0,51	0,63	0,75	1,01	1,31	1,64	2,00	2,39	2,81
h_{ef}/d	12	13	14	15	16	17	18	19	20
$f_{hef} = 0,05 \oplus (h_{ef} / d)^{68}$	3,25	3,72	4,21	4,73	5,27	5,84	6,42	7,04	7,67

Influence of edge distance ^{a)}





c/d	4	6	8	10	15	20	30	40
$f_c = (d / c)^{0,19}$	0,77	0,71	0,67	0,65	0,60	0,57	0,52	0,50

a) The edge distance shall not be smaller than the minimum edge distance c_{min} .

Combined TENSION and SHEAR loading

For combined tension and shear loading see section "Anchor Design".

Hilti HIT-HY 200 with HIS-(R)N

Injection mortar system		Benefits
	Hilti HIT-HY 200-A 500 ml foil pack (also available as 330 ml)	<ul style="list-style-type: none"> - Suitable for cracked and non-cracked concrete C 20/25 to C 50/60. - Suitable for dry and water saturated concrete - High loading capacity, excellent handling, and fast curing - Small edge distance and anchor spacing possible - Corrosion resistant - In service temperature range up to 120°C short term/72°C long term - Manual cleaning for anchor size M8 and M10 - Two mortar (A and R) versions available with different curing times and same performance
	Hilti HIT-HY 200-R 500 ml foil pack (also available as 330 ml)	
	Static mixer	
	Internal threaded sleeve HIS-N HIS-RN	



Concrete



Tensile zone



Small edge distance and spacing



Corrosion resistance



European Technical Approval



CE conformity



PROFIS Anchor design software

Approvals / certificates

Description	Authority / Laboratory	No. / date of issue
European technical approval ^{a)}	DIBt, Berlin	ETA-11/0493 / 2012-08-08 (Hilti HIT-HY 200-A) ETA-12/0084 / 2012-08-08 (Hilti HIT-HY 200-R)

a) All data given in this section according ETA-11/0493 and ETA-12/0084, issue 2012-08-08.

Basic loading data (for a single anchor)

All data in this section applies to

- Correct setting (See setting instruction)
- No edge distance and spacing influence
- Steel failure
- Base material thickness, as specified in the table
- One anchor material, as specified in the tables
- Concrete C 20/25, $f_{ck,cube} = 25 \text{ N/mm}^2$
- Temperature range I
(min. base material temperature -40°C , max. long term/short term base material temperature: $+24^\circ\text{C}/40^\circ\text{C}$)
- Installation temperature range -10°C to $+40^\circ\text{C}$

For details see Simplified design method

Embedment depth and base material thickness for the basic loading data. Mean ultimate, characteristic, design resistance, recommended loads.

Anchor size		M8x90	M10x110	M12x125	M16x170	M20x205
Embedment depth h_{ef} [mm]		90	110	125	170	205
Base material thickness h [mm]		120	150	170	230	270

Mean ultimate: concrete C 20/25 , anchor HIS-N with screw 8.8

Anchor size		M8x90	M10x110	M12x125	M16x170	M20x205
Non cracked concrete						
Tensile $N_{R,u,m}$ HIS-N	[kN]	26,3	48,3	70,4	123,9	114,5
Shear $V_{R,u,m}$ HIS-N	[kN]	13,7	24,2	41,0	62,0	57,8
Cracked concrete						
Tensile $N_{R,u,m}$ HIS-N	[kN]	26,3	48,3	66,8	105,9	114,5
Shear $V_{R,u,m}$ HIS-N	[kN]	13,7	24,2	41,0	62,0	57,8

Characteristic: concrete C 20/25 , anchor HIS-N with screw 8.8

Anchor size		M8x90	M10x110	M12x125	M16x170	M20x205
Non cracked concrete						
Tensile N_{Rk} HIS-N	[kN]	25,0	46,0	67,0	111,9	109,0
Shear V_{Rk} HIS-N	[kN]	13,0	23,0	39,0	59,0	55,0
Cracked concrete						
Tensile $N_{R,u,m}$ HIS-N	[kN]	24,7	39,9	50,3	79,8	105,7
Shear $V_{R,u,m}$ HIS-N	[kN]	13,0	23,0	39,0	59,0	55,0

Design resistance: concrete C 20/25 , anchor HIS-N with screw 8.8

Anchor size		M8x90	M10x110	M12x125	M16x170	M20x205
Cracked concrete						
Tensile N_{Rd} HIS-N	[kN]	17,5	30,7	44,7	74,6	74,1
Shear V_{Rd} HIS-N	[kN]	10,4	18,4	26,0	39,3	36,7
Non cracked concrete						
Tensile $N_{R,u,m}$ HIS-N	[kN]	16,5	26,6	33,5	53,2	70,4
Shear $V_{R,u,m}$ HIS-N	[kN]	10,4	18,4	26,0	39,3	36,7

Recommended loads ^{a)}: concrete C 20/25 , anchor HIS-N with screw 8.8

Anchor size			M8x90	M10x110	M12x125	M16x170	M20x205
Non cracked concrete							
Tensile N_{rec}	HIS-N	[kN]	8,3	15,3	22,3	37,3	36,3
Shear V_{rec}	HIS-N	[kN]	4,3	7,6	13,0	19,7	18,3
Cracked concrete							
Tensile $N_{Ru,m}$	HIS-N	[kN]	8,2	13,0	16,8	26,6	35,2
Shear $V_{Ru,m}$	HIS-N	[kN]	4,3	7,6	13,0	19,7	18,3

a) With overall global safety factor $\gamma = 3,0$. The recommended loads vary according to the safety factor requirement from national regulations.

Service temperature range

Hilti HIT-HY 200 injection mortar may be applied in the temperature ranges given below. An elevated base material temperature may lead to a reduction of the design bond resistance.

Temperature range	Base material temperature	Maximum long term base material temperature	Maximum short term base material temperature
Temperature range I	-40°C to +40°C	+24°C	+40°C
Temperature range II	-40°C to +80°C	+50°C	+80°C
Temperature range III	-40°C to +120°C	+72°C	+120°C

Max short term base material temperature

Short-term elevated base material temperatures are those that occur over brief intervals, e.g. as a result of diurnal cycling.

Max long term base material temperature

Long-term elevated base material temperatures are roughly constant over significant periods of time.

Materials

Mechanical properties of HIS-(R)N

Anchor size			M8x90	M10x110	M12x125	M16x170	M20x205
Nominal tensile strength f_{tk}	HIS-N	[N/mm ²]	490	460	460	460	460
	Screw 8.8	[N/mm ²]	800	800	800	800	800
	HIS-RN	[N/mm ²]	700	700	700	700	700
	Screw A4-70	[N/mm ²]	700	700	700	700	700
Yield strength f_{yk}	HIS-N	[N/mm ²]	410	375	375	375	375
	Screw 8.8	[N/mm ²]	640	640	640	640	640
	HIS-RN	[N/mm ²]	350	350	350	350	350
	Screw A4-70	[N/mm ²]	450	450	450	450	450
Stressed cross-section A_s	HIS-(R)N	[mm ²]	51,5	108,0	169,1	256,1	237,6
	Screw	[mm ²]	36,6	58	84,3	157	245
Moment of resistance W	HIS-(R)N	[mm ³]	145	430	840	1595	1543
	Screw	[mm ³]	31,2	62,3	109	277	541

Material quality

Part	Material
Internal threaded sleeve ^{a)} HIS-N	C-steel 1.0718, Steel galvanized $\geq 5\mu\text{m}$
Internal threaded sleeve ^{b)} HIS-RN	Stainless steel 1.4401 and 1.4571

- a) related fastening screw: strength class 8.8, A5 > 8% Ductile steel galvanized $\geq 5\mu\text{m}$
- b) related fastening screw: strength class 70, A5 > 8% Ductile stainless steel 1.4401; 1.4404; 1.4578; 1.4571; 1.4439; 1.4362

Anchor dimensions

Anchor size	M8x90	M10x110	M12x125	M16x170	M20x205
Internal threaded sleeve HIS-N / HIS-RN					
Embedment depth h_{ef} [mm]	90	110	125	170	205

Setting

Installation equipment

Anchor size	M8x90	M10x110	M12x125	M16x170	M20x205
Rotary hammer	TE 2 – TE 16		TE 40 – TE 70		
Other tools	compressed air gun or blow out pump, set of cleaning brushes, dispenser				

Setting instruction

Bore hole drilling

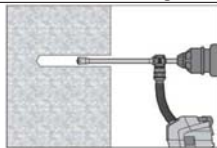

Drill hole to the required embedment depth with an appropriately sized Hilti TE-CD or TE-YD hollow drill bit with Hilti vacuum attachment. This drilling method properly cleans the borehole and removes dust while drilling. After drilling is complete, proceed to the "injection preparation" step in the instructions for use.

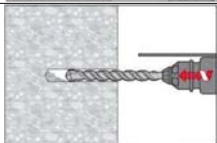

Drill Hole to the required embedment depth with a hammer drill set in rotation-hammer mode using an appropriately sized carbide drill bit.

Bore hole cleaning Just before setting an anchor, the bore hole must be free of dust and debris.

a) Manual Cleaning (MC) non-cracked concrete only

for bore hole diameters $d_0 \leq 20\text{mm}$ and bore hole depth $h_0 \leq 10d$

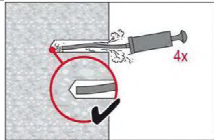

The Hilti manual pump may be used for blowing out bore holes up to diameters $d_0 \leq 20\text{ mm}$ and embedment depths up to $h_{ef} \leq 10d$. Blow out at least 4 times from the back of the bore hole until return air stream is free of noticeable dust

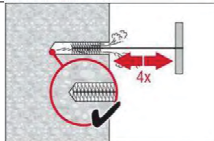

Brush 4 times with the specified brush size by inserting the steel brush Hilti HIT-RB to the back of the hole (if needed with extension) in a twisting motion and removing it. The brush must produce natural resistance as it enters the bore hole -- if not the brush is too small and must be replaced with the proper brush diameter.

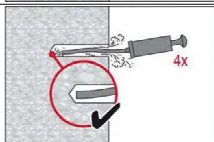

Blow out again with manual pump at least 4 times until return air stream is free of noticeable dust.

b) Compressed air cleaning (CAC)

for all bore hole diameters d_0 and all bore hole depth h_0

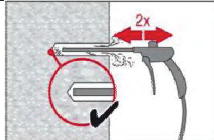

Blow 2 times from the back of the hole (if needed with nozzle extension) over the hole length with oil-free compressed air (min. 6 bar at $6\text{ m}^3/\text{h}$) until return air stream is free of noticeable dust.

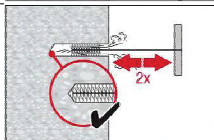

Brush 2 times with the specified brush size by inserting the steel brush Hilti HIT-RB to the back of the hole (if needed with extension) in a twisting motion and removing it. The brush must produce natural resistance as it enters the bore hole -- if not the brush is too small and must be replaced with the proper brush diameter.

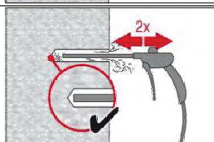

Blow again with compressed air 2 times until return air stream is free of noticeable dust.

Injection preparation

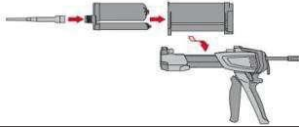

Tightly attach new Hilti mixing nozzle HIT-RE-M to foil pack manifold (snug fit). Do not modify the mixing nozzle. Observe the instruction for use of the dispenser. Check foil pack holder for proper function. Do not use damaged foil packs / holders. Swing foil pack holder with foil pack into HIT-dispenser.



Discard initial adhesive. The foil pack opens automatically as dispensing is initiated. Depending on the size of the foil pack an initial amount of adhesive has to be discarded.

Discard quantities are
 2 strokes for 330 ml foil pack,
 3 strokes for 500 ml foil pack,
 4 strokes for 500 ml foil pack $\leq 5^{\circ}\text{C}$.

Inject adhesive from the back of the borehole without forming air voids

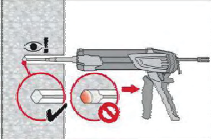

Inject the adhesive starting at the back of the hole, slowly withdrawing the mixer with each trigger pull. Fill holes approximately 2/3 full, or as required to ensure that the annular gap between the anchor and the concrete is completely filled with adhesive along the embedment length.

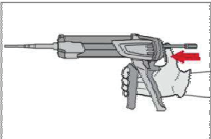

After injection is completed, depressurize the dispenser by pressing the release trigger. This will prevent further adhesive discharge from the mixer.

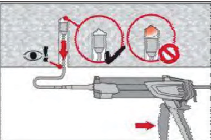

Overhead installation.

For overhead installation the injection is only possible with the aid of extensions and piston plugs. Assemble HIT-RE-M mixer, extension(s) and appropriately sized piston plug. Insert piston plug to back of the hole and inject adhesive. During injection the piston plug will be naturally extruded out of the bore hole by the adhesive pressure.

Setting the element

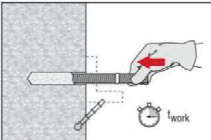

Before use, verify that the element is dry and free of oil and other contaminants.

Mark and set element to the required embedment depth until working time t_{work} has elapsed.

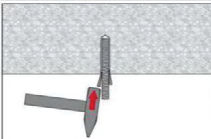

For overhead installation use piston plugs and fix embedded parts with e.g. wedges

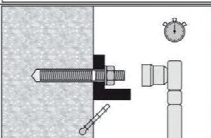

Loading the anchor:

After required curing time t_{cure} the anchor can be loaded.

The applied installation torque shall not exceed T_{max} .

For detailed information on installation see instruction for use given with the package of the product.

Working time, curing time

Temperature of the base material	Hilti HIT-HY 200-R	
	Working time in which anchor can be inserted and adjusted t_{work}	Curing time before anchor can be fully loaded t_{cure}
-10°C to -5°C	3 hour	20 hour
-4°C to 0°C	2 hour	7 hour
1°C to 5°C	1 hour	3 hour
6°C to 10°C	40 min	2 hour
11°C to 20°C	15 min	1 hour
21°C to 30°C	9 min	1 hour
31°C to 40°C	6 min	1 hour

Temperature of the base material	Hilti HIT-HY 200-A	
	Working time in which anchor can be inserted and adjusted t_{work}	Curing time before anchor can be fully loaded t_{cure}
-10°C to -5°C	1,5 hour	7 hour
-4°C to 0°C	50 min	4 hour
1°C to 5°C	25 min	2 hour
6°C to 10°C	15 min	1 hour
11°C to 20°C	7 min	30 min
21°C to 30°C	4 min	30 min
31°C to 40°C	3 min	30 min

Setting details

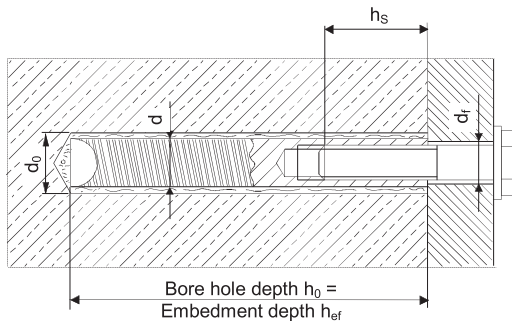

Anchor size		M8x90	M10x110	M12x125	M16x170	M20x205
Nominal diameter of drill bit	d_0 [mm]	14	18	22	28	32
Diameter of element	d [mm]	12,5	16,5	20,5	25,4	27,6
Effective anchorage and drill hole depth	h_{ef} [mm]	90	110	125	170	205
Minimum base material thickness	h_{min} [mm]	120	150	170	230	270
Diameter of clearance hole in the fixture	d_f [mm]	9	12	14	18	22
Thread engagement length; min - max	h_s [mm]	8-20	10-25	12-30	16-40	20-50
Torque moment ^{a)}	T_{max} [Nm]	10	20	40	80	150
Minimum spacing	s_{min} [mm]	40	45	55	65	90
Minimum edge distance	c_{min} [mm]	40	45	55	65	90
Critical spacing for splitting failure	$s_{cr,sp}$ [mm]	$2 c_{cr,sp}$				
Critical edge distance for splitting failure ^{b)}	$c_{cr,sp}$ [mm]	$1,0 \cdot h_{ef}$ for $h / h_{ef} \geq 2,0$				
		$4,6 h_{ef} - 1,8 h$ for $2,0 > h / h_{ef} > 1,3$				
		$2,26 h_{ef}$ for $h / h_{ef} \leq 1,3$				
Critical spacing for concrete cone failure	$s_{cr,N}$ [mm]	$2 c_{cr,N}$				
Critical edge distance for concrete cone failure ^{c)}	$c_{cr,N}$ [mm]	$1,5 h_{ef}$				

For spacing (or edge distance) smaller than critical spacing (or critical edge distance) the design loads have to be reduced.

- a) Maximum recommended torque moment to avoid splitting failure during installation with minimum spacing and/or edge distance.
- b) h : base material thickness ($h \geq h_{min}$), h_{ef} : embedment depth
- c) The critical edge distance for concrete cone failure depends on the embedment depth h_{ef} and the design bond resistance. The simplified formula given in this table is on the safe side.

Simplified design method

Simplified version of the design method according ETAG 001, TR 029. Design resistance according data given in ETA-11/0493 issued 2012-08-08 for HIT-HY 200-A and ETA-12/0084 issued 2012-08-08 for HIT-HY 200-R. Both mortars possess identical technical load performance.

- Influence of concrete strength
- Influence of edge distance
- Influence of spacing
- Valid for a group of two anchors. (The method may also be applied for anchor groups with more than two anchors or more than one edge distance. The influencing factors must then be considered for each edge distance and spacing. The simplified calculated design loads take a conservative approach: They will be lower than the exact values according to ETAG 001, TR 029. For an optimized design, anchor calculation can be performed using PROFIS anchor design software.

The design method is based on the following simplification:

- No different loads are acting on individual anchors (no eccentricity)

The values are valid for one anchor.

For more complex fastening applications please use the anchor design software PROFIS Anchor.

TENSION loading

The design tensile resistance is the lower value of

- Steel resistance: $N_{Rd,s}$

- Combined pull-out and concrete cone resistance:

$$N_{Rd,p} = N_{Rd,p}^0 \cdot f_{B,p} \cdot f_{1,N} \cdot f_{2,N} \cdot f_{3,N} \cdot f_{h,p} \cdot f_{re,N}$$

- Concrete cone resistance: $N_{Rd,c} = N_{Rd,c}^0 \cdot f_B \cdot f_{1,N} \cdot f_{2,N} \cdot f_{3,N} \cdot f_{h,N} \cdot f_{re,N}$

- Concrete splitting resistance (only non-cracked concrete):

$$N_{Rd,sp} = N_{Rd,c}^0 \cdot f_B \cdot f_{1,sp} \cdot f_{2,sp} \cdot f_{3,sp} \cdot f_{h,N} \cdot f_{re,N}$$

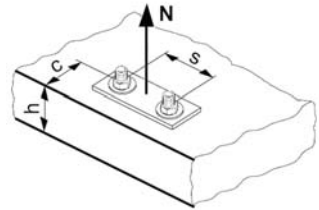

Basic design tensile resistance

Design steel resistance $N_{Rd,s}$

Anchor size		M8x90	M10x110	M12x125	M16x170	M20x205
$N_{Rd,s}$	HIS-N with screw 8.8 [kN]	17,5	30,7	44,7	80,3	74,1
	HIS-RN with screw A4-70 [kN]	13,9	21,9	31,6	58,8	69,2

Design combined pull-out and concrete cone resistance

$$N_{Rd,p} = N_{Rd,p}^0 \cdot f_{B,p} \cdot f_{1,N} \cdot f_{2,N} \cdot f_{3,N} \cdot f_{h,p} \cdot f_{re,N}$$

Anchor size		M8x90	M10x110	M12x125	M16x170	M20x205
Embedment depth	h_{ef} [mm]	90	110	125	170	205
Non cracked concrete						
$N_{Rd,p}^0$	Temperature range I [kN]	30,6	49,4	69,8	117,6	154,7
$N_{Rd,p}^0$	Temperature range II [kN]	25,9	41,8	59,0	99,5	130,4
$N_{Rd,p}^0$	Temperature range III [kN]	22,4	36,1	51,0	85,9	112,6
Cracked concrete						
$N_{Rd,p}^0$	Temperature range I [kN]	16,5	26,6	37,6	63,3	83,0
$N_{Rd,p}^0$	Temperature range II [kN]	13,0	20,9	29,5	49,7	65,2
$N_{Rd,p}^0$	Temperature range III [kN]	11,8	19,0	26,8	45,2	59,3

Design concrete cone resistance $N_{Rd,c} = N_{Rd,c}^0 \cdot f_B \cdot f_{1,N} \cdot f_{2,N} \cdot f_{3,N} \cdot f_{h,N} \cdot f_{re,N}$

Design splitting resistance $N_{Rd,sp} = N_{Rd,sp}^0 \cdot f_B \cdot f_{1,sp} \cdot f_{2,sp} \cdot f_{3,sp} \cdot f_{h,N} \cdot f_{re,N}$

Anchor size		M8	M10	M12	M16	M20
Non cracked concrete						
$N_{Rd,c}^0$	[kN]	28,7	38,8	47,1	74,6	98,8
Cracked concrete						
$N_{Rd,c}^0$	[kN]	20,5	27,7	33,5	53,2	70,4

a) Splitting resistance must only be considered for non-cracked concrete.

Influencing factors

Influence of concrete strength on combined pull-out and concrete cone resistance

Concrete strength designation (ENV 206)	C 20/25	C 25/30	C 30/37	C 35/45	C 40/50	C 45/55	C 50/60
$f_{B,p} = (f_{ck,cube}/25N/mm^2)^{0,10 \text{ a)}$	$f_{B,p} = 1$						

a) $f_{ck,cube}$ = concrete compressive strength, measured on cubes with 150 mm side length

Influence of embedment depth on combined pull-out and concrete cone resistance

$f_{h,p} = 1$

Influence of concrete strength on concrete cone resistance

Concrete strength designation (ENV 206)	C 20/25	C 25/30	C 30/37	C 35/45	C 40/50	C 45/55	C 50/60
$f_B = (f_{ck,cube}/25N/mm^2)^{0,5 \text{ a)}$	1	1,1	1,22	1,34	1,41	1,48	1,55

a) $f_{ck,cube}$ = concrete compressive strength, measured on cubes with 150 mm side length

Influence of edge distance ^{a)}

$c/c_{cr,N}$	0,1	0,2	0,3	0,4	0,5	0,6	0,7	0,8	0,9	1
$c/c_{cr,sp}$										
$f_{1,N} = 0,7 + 0,3 \cdot c/c_{cr,N} \quad \delta 1$	0,73	0,76	0,79	0,82	0,85	0,88	0,91	0,94	0,97	1
$f_{1,sp} = 0,7 + 0,3 \cdot c/c_{cr,sp} \quad \delta 1$										
$f_{2,N} = 0,5 \cdot (1 + c/c_{cr,N}) \quad \delta 1$	0,55	0,60	0,65	0,70	0,75	0,80	0,85	0,90	0,95	1
$f_{2,sp} = 0,5 \cdot (1 + c/c_{cr,sp}) \quad \delta 1$										

a) The edge distance shall not be smaller than the minimum edge distance c_{min} . These influencing factors must be considered for every edge distance smaller than the critical edge distance.

Influence of anchor spacing ^{a)}

$s/s_{cr,N}$	0,1	0,2	0,3	0,4	0,5	0,6	0,7	0,8	0,9	1
$f_{3,N} = 0,5 \cdot (1 + s/s_{cr,N}) \leq 1$	0,55	0,60	0,65	0,70	0,75	0,80	0,85	0,90	0,95	1
$f_{3,sp} = 0,5 \cdot (1 + s/s_{cr,sp}) \leq 1$										

a) The anchor spacing shall not be smaller than the minimum anchor spacing s_{min} . This influencing factor must be considered for every anchor spacing.

Influence of embedment depth on concrete cone resistance

$f_{h,N} = 1$

Influence of reinforcement

h_{ef} [mm]	40	50	60	70	80	90	≥ 100
$f_{re,N} = 0,5 + h_{ef}/200\text{mm} \leq 1$	0,7 ^{a)}	0,75 ^{a)}	0,8 ^{a)}	0,85 ^{a)}	0,9 ^{a)}	0,95 ^{a)}	1

a) This factor applies only for dense reinforcement. If in the area of anchorage there is reinforcement with a spacing ≥ 150 mm (any diameter) or with a diameter ≤ 10 mm and a spacing ≥ 100 mm, then a factor $f_{re,N} = 1$ may be applied.

SHEAR loading

The design shear resistance is the lower value of

- Steel resistance: $V_{Rd,s}$
- Concrete pryout resistance: $V_{Rd,cp} = k \cdot \text{lower value of } N_{Rd,p} \text{ and } N_{Rd,c}$
- Concrete edge resistance: $V_{Rd,c} = V_{Rd,c}^0 \cdot f_B \cdot f_{lB} \cdot f_h \cdot f_4 \cdot f_{het} \cdot f_c$

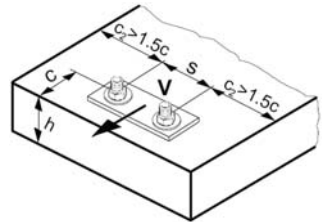

Basic design shear resistance

Design steel resistance $V_{Rd,s}$

Anchor size		M8x90	M10x110	M12x125	M16x170	M20x205
$V_{Rd,s}$	HIS-N with screw 8.8 [kN]	10,4	18,4	26,0	39,3	36,7
	HIS-RN with screw A4-70 [kN]	8,3	12,8	19,2	35,3	41,5

Design concrete pryout resistance $V_{Rd,cp} = \text{lower value}^a)$ of $k \cdot N_{Rd,p}$ and $k \cdot N_{Rd,c}$

$k = 2$

- a) $N_{Rd,p}$: Design combined pull-out and concrete cone resistance
- $N_{Rd,c}$: Design concrete cone resistance

Design concrete edge resistance $V_{Rd,c} = V_{Rd,c}^0 \cdot f_B \cdot f_{\beta} \cdot f_h \cdot f_4 \cdot f_{nef} \cdot f_c$

Anchor size	M8	M10	M12	M16	M20
Non-cracked concrete					
$V_{Rd,c}^0$ [kN]	12,4	19,6	28,2	40,2	46,2
Cracked concrete					
$V_{Rd,c}^0$ [kN]	8,8	13,9	20,0	28,5	32,7

Influencing factors

Influence of concrete strength

Concrete strength designation (ENV 206)	C 20/25	C 25/30	C 30/37	C 35/45	C 40/50	C 45/55	C 50/60
$f_B = (f_{ck,cube}/25N/mm^2)^{1/2}$ a)	1	1,1	1,22	1,34	1,41	1,48	1,55

a) $f_{ck,cube}$ = concrete compressive strength, measured on cubes with 150 mm side length

Influence of angle between load applied and the direction perpendicular to the free edge

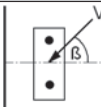
Angle β	0°	10°	20°	30°	40°	50°	60°	70°	80°	≥ 90°
$f_{\beta} = \frac{1}{\sqrt{(\cos \alpha_v)^2 + \left(\frac{\sin \alpha_v}{2,5}\right)^2}}$ 	1	1,01	1,05	1,13	1,24	1,40	1,64	1,97	2,32	2,50

Influence of base material thickness

h/c	0,15	0,3	0,45	0,6	0,75	0,9	1,05	1,2	1,35	≥ 1,5
$f_h = \{h/(1,5 \cdot c)\}^{1/2} \leq 1$	0,32	0,45	0,55	0,63	0,71	0,77	0,84	0,89	0,95	1,00

Influence of anchor spacing and edge distance ^{a)} for concrete edge resistance: f_4
 $f_4 = (c/h_{ef})^{1.5} \cdot (1 + s / [3 \cdot c]) \cdot 0,5$

c/h _{ef}	Single anchor	Group of two anchors s/h _{ef}														
		0,75	1,50	2,25	3,00	3,75	4,50	5,25	6,00	6,75	7,50	8,25	9,00	9,75	10,50	11,25
0,50	0,35	0,27	0,35	0,35	0,35	0,35	0,35	0,35	0,35	0,35	0,35	0,35	0,35	0,35	0,35	0,35
0,75	0,65	0,43	0,54	0,65	0,65	0,65	0,65	0,65	0,65	0,65	0,65	0,65	0,65	0,65	0,65	0,65
1,00	1,00	0,63	0,75	0,88	1,00	1,00	1,00	1,00	1,00	1,00	1,00	1,00	1,00	1,00	1,00	1,00
1,25	1,40	0,84	0,98	1,12	1,26	1,40	1,40	1,40	1,40	1,40	1,40	1,40	1,40	1,40	1,40	1,40
1,50	1,84	1,07	1,22	1,38	1,53	1,68	1,84	1,84	1,84	1,84	1,84	1,84	1,84	1,84	1,84	1,84
1,75	2,32	1,32	1,49	1,65	1,82	1,98	2,15	2,32	2,32	2,32	2,32	2,32	2,32	2,32	2,32	2,32
2,00	2,83	1,59	1,77	1,94	2,12	2,30	2,47	2,65	2,83	2,83	2,83	2,83	2,83	2,83	2,83	2,83
2,25	3,38	1,88	2,06	2,25	2,44	2,63	2,81	3,00	3,19	3,38	3,38	3,38	3,38	3,38	3,38	3,38
2,50	3,95	2,17	2,37	2,57	2,77	2,96	3,16	3,36	3,56	3,76	3,95	3,95	3,95	3,95	3,95	3,95
2,75	4,56	2,49	2,69	2,90	3,11	3,32	3,52	3,73	3,94	4,15	4,35	4,56	4,56	4,56	4,56	4,56
3,00	5,20	2,81	3,03	3,25	3,46	3,68	3,90	4,11	4,33	4,55	4,76	4,98	5,20	5,20	5,20	5,20
3,25	5,86	3,15	3,38	3,61	3,83	4,06	4,28	4,51	4,73	4,96	5,18	5,41	5,63	5,86	5,86	5,86
3,50	6,55	3,51	3,74	3,98	4,21	4,44	4,68	4,91	5,14	5,38	5,61	5,85	6,08	6,31	6,55	6,55
3,75	7,26	3,87	4,12	4,36	4,60	4,84	5,08	5,33	5,57	5,81	6,05	6,29	6,54	6,78	7,02	7,26
4,00	8,00	4,25	4,50	4,75	5,00	5,25	5,50	5,75	6,00	6,25	6,50	6,75	7,00	7,25	7,50	7,75
4,25	8,76	4,64	4,90	5,15	5,41	5,67	5,93	6,18	6,44	6,70	6,96	7,22	7,47	7,73	7,99	8,25
4,50	9,55	5,04	5,30	5,57	5,83	6,10	6,36	6,63	6,89	7,16	7,42	7,69	7,95	8,22	8,49	8,75
4,75	10,35	5,45	5,72	5,99	6,27	6,54	6,81	7,08	7,36	7,63	7,90	8,17	8,45	8,72	8,99	9,26
5,00	11,18	5,87	6,15	6,43	6,71	6,99	7,27	7,55	7,83	8,11	8,39	8,66	8,94	9,22	9,50	9,78
5,25	12,03	6,30	6,59	6,87	7,16	7,45	7,73	8,02	8,31	8,59	8,88	9,17	9,45	9,74	10,02	10,31
5,50	12,90	6,74	7,04	7,33	7,62	7,92	8,21	8,50	8,79	9,09	9,38	9,67	9,97	10,26	10,55	10,85

a) The anchor spacing and the edge distance shall not be smaller than the minimum anchor spacing s_{min} and the minimum edge distance c_{min} .

Influence of embedment depth

Anchor size	M8	M10	M12	M16	M20
$f_{hef} =$	1,38	1,21	1,04	1,22	1,45

Influence of edge distance ^{a)}

c/d	4	6	8	10	15	20	30	40
$f_c = (d/c)^{0,19}$	0,77	0,71	0,67	0,65	0,60	0,57	0,52	0,50

a) The edge distance shall not be smaller than the minimum edge distance c_{min} .

Combined TENSION and SHEAR loading

For combined tension and shear loading see section "Anchor Design".

