



Hilti CP 606 Firestop Acrylic

Sealant Submission Folder

Product Information and Method Statement	2
Test Reports	
Top of Wall Joint	
- RED No. R22D26-1A	7
Pipe Penetration	
- RED No. R23A14-1A	31
- IA23-036	51
Door Frame	
RED No. R22D25-1A Issue 1	64
General	
- VOC Content	76
Letters	
Government Letters	77
Country of Origin	80
LEED Letter	81
BEAM Plus Information	82
Material Safety Data Sheet	83
Job Reference	90



Recycling one ton of paper saves 17 trees and 7000 gallons of water.
Please consider your environmental responsibility before using the hard copy version!

Flexible firestop sealant CP 606



APPLICATIONS

- Sealant rigid or low movement ceiling / wall joints, up to 30mm
- Sealing metal pipe penetrations
- For use in various base materials such as masonry, concrete, drywall and metal

ADVANTAGES

- Paintable
- Easy to clean up with water
- Smoke, fume and water resistant



Technical data

Chemical basis	Water-based acrylic dispersion
Base materials	Concrete, Masonry, Drywall, Steel
Movement¹⁾	±12.5% (ISO 11600)
Approx. tack-free time (ventilated at 77°F, 80% rel. humidity)	20 min
Approx. curing time²⁾	3 mm/3 days
Average volume shrinkage	22.2%
Application temperature range	5 - 40 °C
Temperature resistance range	-30 - 80 °C
Storage and transportation temperature range	5 - 25 °C
Shelf life³⁾	24 Months

¹⁾ according to HTC 1250

²⁾ at 75°F/24°C, 50% relative humidity

³⁾ at 77°F/25°C and 50% relative humidity; from date of manufacture



Consumption Guide

Cartridge volume = 310 ml (CP 606)

a = Joint width in mm

b = Sealant depth in mm

Linear metre per cartridge = $\frac{\text{Cartridge volume in ml}}{a \times b}$

e.g. a floor 20mm wide with product depth of 10mm; with 310ml cartridge
Therefore linear metres per cartridge = $310/(20 \times 10) = 1.55$ metre per cartridge for one side of the floor

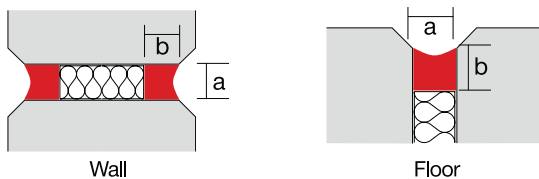

Joint width (mm)	0-15	16-20	21-30
Sealant depth (mm)	6	10	15

Application Procedure

Joint installation

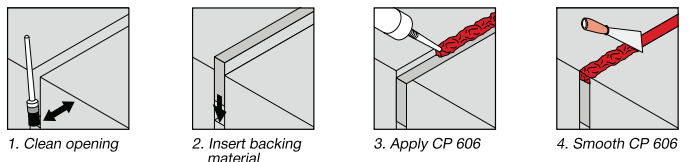

Pipe installation (non-combustible pipes only)

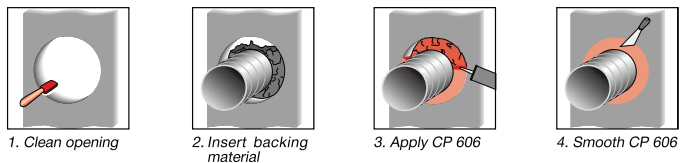

Order Now



Ordering designation	Colour	Volume per unit	Packaging	Sales pack quantity	Item number
CP 606 310ml INT grey	Grey	310 ml	Cartridge	1 pc	209630
CP 606 580ml INT grey	Grey	580 ml	Foil pack	1 pc	209633
CP 606 310ml white	white	310 ml	Cartridge	1 pc	209625
CP 606 580ml white	white	580 ml	Foil pack	1 pc	209632

Please visit Hilti website for the latest item numbers and related products

Subject: Method Statement of CP 606 for Penetration Seal.
Material: CP 606 firestop sealant
Accessory: Hilti Dispenser CFS-DISP or Hilti Dispenser CS 270-P1 or equivalent.

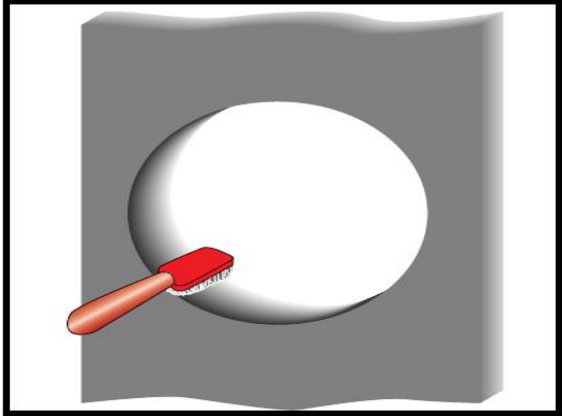
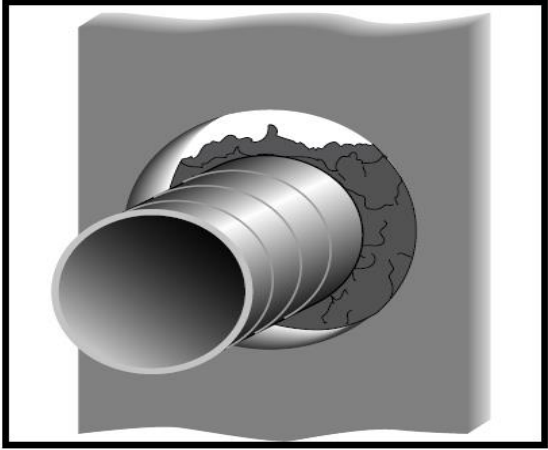
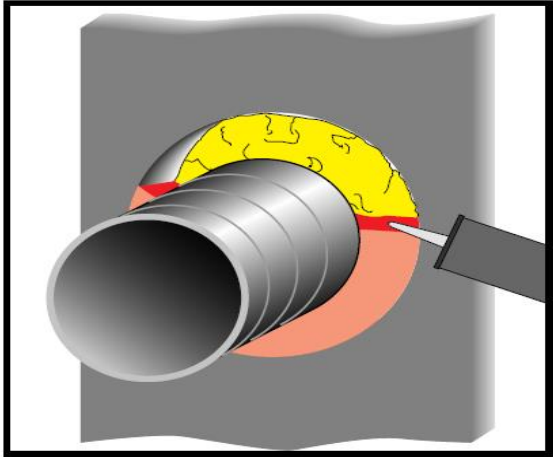
Setting Operation		
1	Clean the opening. Joint sides and surfaces to which CP 606 will be applied must be sound, dry and free from dust, oil and grease.	
2	Insert the required fill of mineral wool and backer.	
3	Apply firestop CP 606 over backer.	

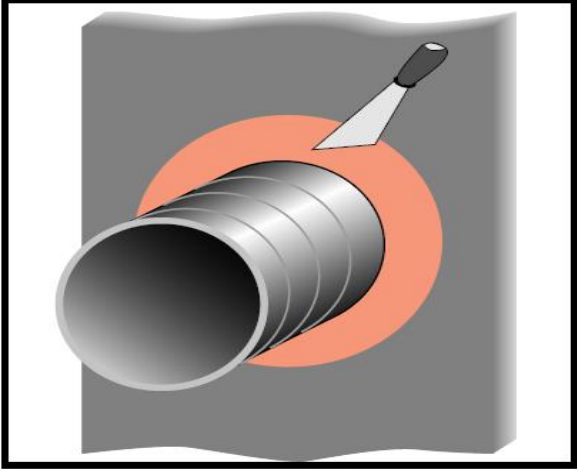
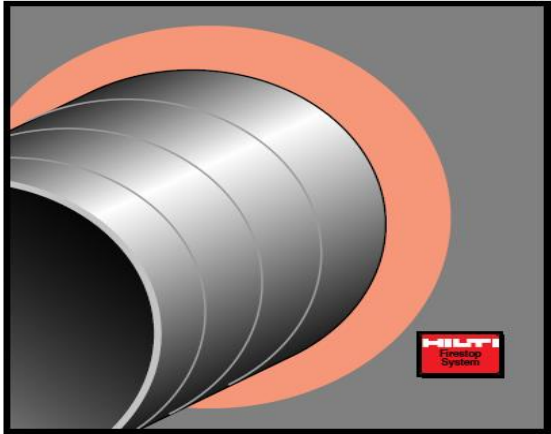
4	<p>Smooth the firestop sealant with a trowel before the skin forms. Once cured, CP 606 can only be removed mechanically.</p>	 A 3D perspective illustration of a grey metal pipe protruding from a grey wall. An orange firestop sealant is applied around the pipe's circumference. A white trowel with a black handle is shown smoothing the sealant. The background is a dark grey gradient.
5	<p>For maintenance reasons, a penetration seal could be permanently marked with an identification plate. In such a case, mark the identification plate and fasten it in a visible position next to the seal.</p>	 A 3D perspective illustration of a grey metal pipe protruding from a grey wall. An orange firestop sealant is applied around the pipe's circumference. A small red identification plate with the HILTI logo and the text 'Firestop Systems' is fastened to the wall next to the sealant. The background is a dark grey gradient.

Safety precautions:

- Never use in areas immersed in water
- Keep out of reach of children
- Read the Material Safety Data Sheet
- Eyes and hands must be suitably protected
- Avoid contact with eyes or skin
- Only use in well ventilated areas

Subject: Method Statement of CP 606 for Linear Joint Seal
Material: CP 606 firestop sealant
Accessory: Hilti Dispenser CFS-DISP or Hilti Dispenser CS 270-P1 or equivalent.

Setting Operation		
1	Clean the opening. Joint sides and surfaces to which CP 606 will be applied must be sound, dry and free from dust, oil and grease.	<p>A diagram showing a brush being used to clean the joint surface. The brush is positioned at the corner of a joint, and a double-headed arrow indicates the cleaning motion.</p>
2	Insert fill of mineral wool or backing material (if required)	<p>A diagram showing a yellow rectangular block of mineral wool or backing material being inserted into the joint. A downward-pointing arrow indicates the direction of insertion.</p>
3	Apply CP 606 over the backing material .	<p>A diagram showing a Hilti dispenser applying red CP 606 sealant over the yellow backing material. The dispenser nozzle is shown extruding the sealant into the joint.</p>

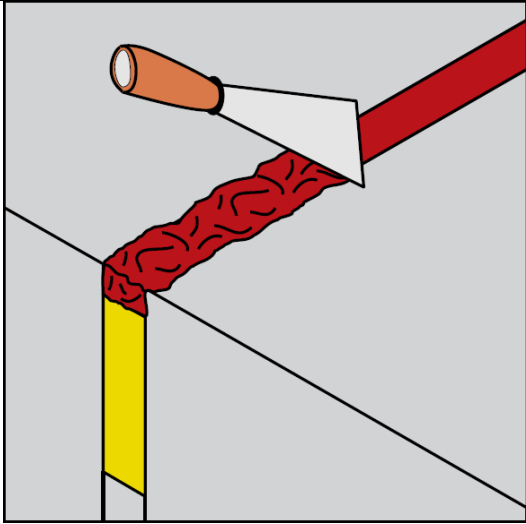
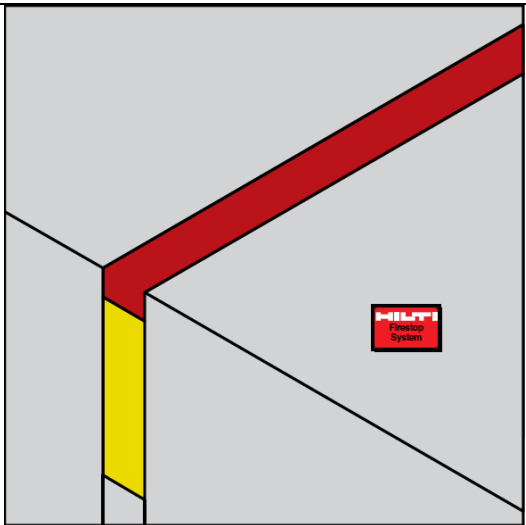
4	Smooth CP 606 using a trowel before the skin forms. It can only be removed mechanically once it is cured.	 A diagram showing a corner joint where a red sealant is being applied. A trowel with a wooden handle is shown smoothing the sealant. The sealant is being applied to a yellow vertical surface and a grey horizontal surface. The sealant is shown in a textured, uncured state.
5	For maintenance reasons, a penetration seal would be permanently marked with an identification plate. In such a case, mark the identification plate and fasten it in a visible position next to the seal	 A diagram showing a corner joint where a red sealant is applied. The sealant is now smooth and cured. A small red identification plate with the HILTI logo and the text 'Firestop System' is fastened to the wall next to the sealant. The sealant is applied to a yellow vertical surface and a grey horizontal surface.

Safety precautions:

- Never use in areas immersed in water
- Keep out of reach of children
- Read the Material Safety Data Sheet
- Eyes and hands must be suitably protected
- Avoid contact with eyes or skin
- Only use in well ventilated areas

ASSESSMENT REPORT

The use of Hilti “CP606” and “CP601S” Firestop Sealant for Linear Joint Seals

Report No.: R22D26-1A

Issue Date: 19 May, 2022

Date of Review: 18 May, 2025

Report Sponsor

Hilti (Hong Kong) Limited
701-704 & 708B, Tower A Manulife Finance Centre,
223 Wai Yip Street, Kwun Tong, Kowloon, HK

This report only relates to the specimen(s) tested and may only be reproduced by the sponsor in full, without comment, abridgement and modifications.

CONTENT

Section	Description	Page
1	INTRODUCTION	3
2	ASSUMPTIONS	3
3	SUPPORTING DATA	4
4	PROPOSAL & DISCUSSION	11
5	CONCLUSION	22
6	DECLARATION BY APPLICANT	22
7	VALIDITY	22
8	SIGNATORIES	22
APPENDIX A – SUMMARY OF APPLICATION OF SEALANTS IN DIFFERENT SCENARIOS		23

REVISION HISTORY

Issue date (DD/MM/YYYY)	Issue number	Remark
19/05/2022	0	Initial version

THE USE OF HILTI “CP606” AND “CP601S” FIRESTOP SEALANT FOR LINEAR JOINT SEALING

1 INTRODUCTION

This assessment report presents an appraisal for the use of the Hilti “CP606” and “CP601S” sealant for linear joint sealing purpose in either floor mounted or wall mounted situation. The appraisal will be based on the test evidence as shown in section 3 of this report. This report is prepared for Hilti (Hong Kong) Limited of 701-704 & 708B, Tower A, Manulife Finance Centre, 223 Wai Yip Street, Kwun Tong, Kowloon, HK.

The proposed linear joint sealing system are required to provide a fire resistance performance of up to 240 minutes integrity and insulation with respect to BS 476: Part 20: 1987.

2 ASSUMPTIONS

The proposed systems are assumed to be installed in a similar manner to that of the previously tested system by competent installers. It is assumed that the modified systems will be constructed in a similar manner from materials and components of the same manufacture and equivalent quality as tested with supporting test evidence or otherwise appraised by RED. Further assumptions related to the specific modifications will be stated in the report.

It is also assumed that the supporting structures to which the perimeter of the systems will be fixed are capable of supporting the proposed structure effectively.

Assuming that the issue of the original test report is valid, the current testing standard or testing experience has not been changed and the procedures adopted for the original report have been re-examined and reviewed that there have been no changes to the specification of the construction considered in the original report. If contradictory data or any related evidence becomes available to RED, the assessment will be unconditionally withdrawn and the sponsor will be notified. This report is based on the given information, in which is declared by report sponsor that no contradictory data has become available.

3 SUPPORTING DATA

3.1 Summary of Supporting Test Evidence

Report no.	Sections	Description
Primary Test Evidence		
WF report no. 146725 Issue 2	4.1	Supporting test evidence for the use of the Hilti "CP606" sealant for the purpose of sealing wall mounted linear gap joint. The test was conducted in accordance with BS EN 1363-1.
WARRES report no. 69754/C	4.1	Supporting test evidence for the use of the Hilti "CP606" sealant for the purpose of sealing floor mounted linear gap joint. The test was conducted in accordance with BS 476: Part 20.
WARRES report no. 71151/A	4.1	Supporting test evidence for the use of the Hilti "CP606" sealant for the purpose of sealing wall mounted linear gap joint. The test was conducted in accordance with BS 476: Part 20.
WARRES report no. 71151/B	4.1	Supporting test evidence for the use of the Hilti "CP606" and "CP601S" sealant for the purpose of sealing floor mounted linear gap joint. The test was conducted in accordance with BS 476: Part 20.
WF report no. 143653	4.1	Supporting test evidence for the use of the Hilti "CP601S" sealant for the purpose of sealing wall or floor mounted linear gap joint. The test was conducted in accordance with BS 476: Part 20.
Secondary Test Evidence		
97R1 3024C	4.1	Supporting test evidence for the use of the Hilti "CP606" and "CP601S" sealant for the purpose of sealing wall mounted linear gap joint. The test was conducted in accordance with ISO 834.

3.2 Primary Test Evidences

3.2.1 Warringtonfire Test Report No. 146725 Issue 2#

A fire resistance test in accordance with BS EN 1366-3: 2004 and utilising the general principles of BS EN 1363-1: 1999 to evaluate the fire resistance performance of eighteen specimens of penetration sealing systems (referenced 1 to 18), and three linear gap sealing systems (referenced A to C) was performed by the Warringtonfire testing laboratory on 15th July, 2005. The report was prepared for Hilti (Great Britain) Limited, the Hilti Entwicklungsgesellschaft mbH had given permission to use this data.

In this assessment report, only the specimens "A" to "C" were considered.

In this test, specimens "A" and "B" were vertically orientated liner gap seals had nominal sizes of 1,000 mm by 30 mm and incorporated a galvanised mild steel angle fitted to one face. Specimen A was sealed on each face with "CP 606" and a Polyethylene backing rod. Specimen "B" was infilled with mineral wool and sealed on each face with "CP606".

Specimen C had overall nominal dimensions of 1,000 mm by 50 mm and incorporated a galvanised mild steel angle on its lower face. The gap was sealed on its exposed face with "CP606" and two Polyethylene backing rods.

The specimens satisfied the performance requirements specified in BS EN 1363-1 and BS EN 1366-3 for the following periods:

Specimen 'A'

Integrity: 241 Minutes (No failure)

Insulation: 106 Minutes

Specimen 'B'

Integrity: 241 Minutes (No failure)

Insulation: 100 Minutes

Specimen 'C'

Integrity: 40 Minutes

Insulation: 8 Minutes

The test was discontinued after a heating period of 241 minutes (See WF report no. 146725 Issue 2 for full details).

#Note: the test data is more than five years old; we have reviewed this data against the current test procedures as per BS EN 1363-1: 1999 and found it suitable for this assessment.

3.2.2 WARRES Test Report No. 69754/C*

A fire resistance test on four specimens of proprietary gap sealing systems incorporated between various floor sections used the general principles of BS 476: Part 20: 1987 and in conjunction with additional guidelines from the draft document CENT/TC127 N579 was performed at the WARRES laboratory on 14th November 1996. The test sponsor was Hilt Ag, the Hilti Entwicklungsgesellschaft mbH had given permission to use this data.

The test was performed on four different specimens of gap sealing systems referenced 1 to 4 for the purposes of the test. Three specimens were incorporated between aerated concrete gap faces, the fourth between steel gap faces. The gap referenced 1 and 2 were of nominal width 20 mm, those referenced 3 and 4 were of nominal width 30 mm, all were of nominal length 950 mm. Each gap was sealed using Hilti CP606 in conjunction with a proprietary backing material.

The performance of each specimen assessed against the integrity and insulation (maximum temperature rise) criteria of BS 476: Part 20: 1987, the results were expressed as follow:

Specimen Ref:	Gap Width (mm)	Gap Faces	CP606 Depth	Backing Material	Integrity (Min)	Insulation (Min)
1	20	AAC/AAC	10	PE	240	130
2	20	AAC/AAC	15	CF 125-50	240	208
3	30	Steel/Steel	15	Rockfibre	240	36
4	30	AAC/AAC	15	Rockfibre	240	216

The test was discontinued after a period of 240 minutes (See WARRES no. 69754/C for full details).

*Note: the test data is more than five years old; we have reviewed this data against the current test procedures as per BS 476: Part 20: 1987 and found it suitable for this assessment.

3.2.3 WARRES Test Report No. 71151/A*

A fire resistance test stated to be in accordance with BS 476: Part 20: 1987 on five different specimens of proprietary gap sealing system was performance by the Warringtonfire testing laboratory on 25th April, 1997. The report was prepared for Hilti GmbH, the Hilti Entwicklungsgesellschaft mbH had given permission to use this data.

The specimens were referenced "V1" to "V5" for the purpose of the test. Specimens "V1" and "V2" were comprised of an 80 mm deep layer of Rockfibre faced on both sides with a layer of 10 mm thick 'Hilti CP606'. The specimens were installed in a nominally 65 mm high gap between a simulated partition wall head and a steel composite deck above.

Specimen "V3" was comprised of a 90 mm deep layer of rockfibre faced on both sides with a layer of 5 mm thick 'Hilti CP606'. The specimen was installed in a nominally 65 mm high gap between a simulated partition wall head and a steel composite deck above.

Specimens "V4" and "V5" were comprised a gap seal for use at a partition wall fixed edge detail. Specimen "V4" consisted of a 25 mm deep by 10 mm wide aperture at both sides infilled with a 15 mm deep layer of rockfibre and faced with a layer of 10 mm thick 'Hilti CP606'. Specimen "V5" consisted of a 25 mm deep by 5 mm wide aperture at both sides infilled with a 20 mm deep layer of rock fibre and faced with a layer of 5 mm thick 'Hilti CP 606'.

The specimen satisfied the performance requirements specified in BS 476: Part 20: 1987 for the following periods:

Specimen ref:	Integrity (mins)	Insulation (mins)
V1	136	136
V2	136	136
V3	136	135
V4	136	136
V5	136	136

The test was discontinued after a heating period of 242 minutes[@] (See WARRES test report no. 71151/C for full details).

*Note: The test data is more than five years old; we have reviewed this data against the current test procedures as per BS 476: Part 20: 1987 and found it suitable for this assessment.

@Note: The test include the horizontally mounted specimen at the same time, after 136 minutes, the specimens "V1" to V3" were covered with a layer of ceramic fibre in order to allow the test to continue for the horizontally mounted specimens.

3.2.4 WARRES Test Report No. 71151/B*

A fire resistance test stated to be in accordance with BS 476: Part 20: 1987 on four different specimens of proprietary gap sealing system was performance by the Warringtonfire testing laboratory on 25th April, 1997. The report was prepared for Hilti GmbH, the Hilti Entwicklungsgesellschaft mbH had given permission to use this data.

The specimens were referenced "H1" to "H4" for the purpose of the test. The specimens were incorporated between aerated concrete gap faces. The gaps were of nominal length 900 mm, and were sealed using Hilti CP 606 or CP 601S in conjunction with a rockfibre backing material.

The specimen "H1" was a 15 mm wide linear gap sealed with 6 mm thick Hilti "CP606" backed with rockfibre. The specimen "H2" was a 15 mm wide linear gap sealed with 6 mm thick Hilti "CP601S" backed with rockfibre. The specimen "H3" was a 30 mm wide linear gap sealed with 15 mm thick Hilti "CP601S" backed with rockfibre. The specimen "H4" was a 100 mm wide linear gap sealed with 15 mm thick Hilti "CP601S" backed with rockfibre.

The specimen satisfied the performance requirements specified in BS 476: Part 20: 1987 for the following periods:

Specimen ref:	Integrity (mins)	Insulation (mins)
H1	242	242
H2	242	242
H3	242	242
H4	242	242

The test was discontinued after a heating period of 242 minutes[@] (See WARRES test report no. 71151/B for full details).

*Note: The test data is more than five years old; we have reviewed this data against the current test procedures as per BS 476: Part 20: 1987 and found it suitable for this assessment.

3.2.5 Warringtonfire Test Report No. 143653*

A fire resistance test in accordance with BS 476: Part 20: 1987 to evaluate the fire resistance performance of eight specimens of Hilti “CP601S” linear gap sealing systems (referenced A to H) was performed by the Warringtonfire testing laboratory on 20th December, 2004. The report was prepared for Hilti Entwicklung Befestigungstechnik GmbH, the Hilti Entwicklungsgesellschaft mbH had given permission to use this data.

In this test, specimens “A” to “D” were wall mounted specimens whilst the specimens “E” to “H” were floor mounted specimens.

Specimen “A” was a 50 mm gap width, sealed to both the unexposed face and exposed face with Hilti “CP601S” to a depth of 20 mm, backed with two 50 mm diameter backing rods.

Specimen “B” was a 10 mm gap width, sealed to both the unexposed face and exposed face with Hilti “CP601S” to a depth of 6 mm, backed with two 15 mm diameter backing rods.

Specimen “C” was a 30 mm gap width, sealed to the unexposed face with Hilti “CP601S” to a depth of 15 mm, backed with one 35 mm diameter backing rods.

Specimen “D” was a 10 mm gap width, sealed to the unexposed face with Hilti “CP601S” to a depth of 6 mm, backed with one 15 mm diameter backing rods.

Specimen “E” was a 50 mm gap width, sealed to both the unexposed face and exposed face with Hilti “CP601S” to a depth of 20 mm, backed with two 50 mm diameter backing rods.

Specimen “F” was a 10 mm gap width, sealed to both the unexposed face and exposed face with Hilti “CP601S” to a depth of 6 mm, backed with two 15 mm diameter backing rods.

Specimen “G” was a 30 mm gap width, sealed to the unexposed face with Hilti “CP601S” to a depth of 15 mm, backed with one 35 mm diameter backing rods.

Specimen “H” was a 10 mm gap width, sealed to the unexposed face with Hilti “CP601S” to a depth of 6 mm, backed with one 15 mm diameter backing rods.

The specimens satisfied the performance requirements specified in BS EN 1363-1 and BS EN 1366-3 for the following periods:

Specimen ref:	Integrity (mins)	Insulation (mins)	Specimen ref:	Integrity (mins)	Insulation (mins)
A	240	240	E	240	240
B	240	240	F	240	240
C	240	96	G	240	126
D	240	240	H	240	240

The test was discontinued after a heating period of 240 minutes (See WF report no. 143653 for full details).

*Note: the test data is more than five years old; we have reviewed this data against the current test procedures as per BS 476: Part 20: 1987 and found it suitable for this assessment.

3.3 Secondary Test Evidence

3.3.1 SP Test Report No. 97R1 3024C^

A fire resistance test in accordance with SIS 02 48 20, edition 2 to evaluate the fire resistance performance of the linear gap sealing systems was performed by the SP testing laboratory on 20th November, 1997. The report was prepared for Hilti Svenska AB, the Hilti Entwicklungsgesellschaft mbH had given permission to use this data.

The test described various cable services penetrations sealing, cable penetration sealing systems, pipe service penetrations and linear joint sealing systems. In this appraisal, only the linear joint sealing systems using the "CP601S", reference Joint "11" and "13" were considered.

Joint 11 was the linear gap created to simulate the AAC/Steel interface at the joint. The gap width is 30 mm and applied with 15 mm deep Hilti "CP601S" sealant backed with rockfibre material.

Joint 13 was the linear gap created to simulate Steel/Steel interface at the joint. The gap width is 30 mm and applied with 15 mm deep Hilti "CP601S" sealant backed with rockfibre material.

The specimens satisfied the performance requirements specified in the SIS 02 48 20, edition 2 for the following periods:

Joint '11'

Integrity: 126 Minutes (No failure)

Insulation: 24 Minutes

Joint '13'

Integrity: 82 Minutes (No failure)

Insulation: 24 Minutes

The test was discontinued after a heating period of 126 minutes (See SP report no. 97R1 3024C for full details).

^Note: the test standard SIS 02 48 20 edition 2, was a test standard with the heating and pressure conditions are identical to those specified in BS 476: Part 20: 1987. The test data is therefore considered as acceptable to be used as the secondary test evidence for the use of Hilti CP 601S sealant.

4 PROPOSAL & DISCUSSION

4.1 *The use of test evidences, which were tested in accordance with BS EN 1363-1: 1999, for the assessment of linear joint sealing system to BS 476: Part 20: 1987*

Proposal

It is proposed that the test evidence of WF report no. 146725 Issue 2 for the linear joint seal system, which were tested in accordance with BS EN 1363-1: 1999, is suitable for use in the assessment against BS 476: Part 20: 1987.

Discussion

The fire test on the linear joint seal systems as tested and described in the above test evidence were carried out in accordance with BS EN 1363-1: 1999. In reviewing the tests, we have considered the design and installation of the specimens, the surrounding construction, the initial furnace temperature, the pressure in the furnace, the changes in the integrity criteria and the behaviour of the fire tests, it is expected that if these fire tests had been conducted in accordance with BS 476: Part 20: 1987 very similar results would have been achieved.

Fire tests to BS EN 1363-1: 1999 and BS 476: Part 20: 1987 have the same furnace temperature-time curve, i.e., the standard ISO temperature time curve represented by $T = 345 \log_{10}(8t + 1) + 20$, where T is the furnace temperature rise and t is the time of heating conditions. However, a more severe overpressure requirement of 5 Pa required by BS EN 1363-1: 1999 was used, which was normally deemed to be more onerous. The passing criteria for the standards of BS EN 1363-1: 1999 and BS 476: Part 20: 1987 are summarised as follows:

Integrity. Monitor the unexposed face of the specimen for evaluation of integrity. A failure of the test construction to maintain integrity occurs when collapse or sustained flaming on the unexposed face occurs or impermeability is exceeded.

Insulation. Failure occurs when (a) the mean unexposed face temperature increases by more than 140 °C above its initial value; or (b) the temperature recorded at any position on the unexposed face is in excess of 180 °C above its initial value; or (c) when integrity failure occurs.

Having stated these criteria, there is no significant difference between the tests to BS EN and British standards. Since the integrity and insulation criteria of BS EN 1363-1: 1999 are basically the same, we can conservatively conclude that the linear joint sealing system as tested and described in WF report no. 146725 Issue 2 will achieve fire resistance performance not worse than tested if test to BS 476: Part 20: 1987.

4.2 The fire resistance performance of linear joint sealing system using the Hilti “CP606” with respect to BS 476: Part 20: 1987.

Proposal

It is proposed that Hilti ‘CP 606’ may be used for the purpose of linear gap sealing under either the wall mounted or floor mounted situation with the substrate of the linear gap may be of different materials. The installation of the sealant may be backed by rockwool or PE rod. The scope below described the condition of seal application at different scenarios and the outcome fire resistance performance for each specific scenario with respect to BS 476: Part 20: 1987.

- (a) The application of Hilti “CP606” for floor mounted situation with the backing materials being the 130 mm deep by 100 kg/m³ mineral wool and 85 mm deep by 140 kg/m³ mineral wool. The width of the mineral wool shall be slightly wider than the gap width such that the installation of the mineral wool shall be conducted by slight compression. The sealant and the backing materials are applied on the unexposed side only with the heat exposure from underside of the floor only:

Table 4.2.1 – The use of Hilti “CP 606” with rockwool backing in floor mounted situation

Gap width (mm)	Seal Depth (mm)	Gap Faces	Integrity	Insulation
0-15	6	AAC/AAC	240	240
16-20	10	AAC/AAC	240	120
21-30	15	AAC/AAC	240	180
0-15	6	Steel/Steel	240	0
16-20	10	Steel/Steel	240	0
21-30	15	Steel/Steel	240	30
0-15	6	AAC/Steel	240	0
16-20	10	AAC/Steel	240	0
21-30	15	AAC/Steel	240	30

- (b) The application of Hilti “CP606” for floor mounted situation with the backing materials being the PE backer rod with the diameter of the backer rod shall be slightly larger than the gap width as mentioned below and friction fit into the gap. The sealant and the backing materials are applied on the unexposed side only with the heat exposure from underside of the floor only:

Table 4.2.2 – The use of Hilti “CP 606” with PE backer rod in floor mounted situation

Gap width (mm)	Seal Depth (mm)	Gap Faces	Integrity	Insulation
0-15	6	AAC/AAC	120	60
0-20	10	AAC/AAC	240	120
21-30	15	AAC/AAC	240	120

- (c) The application of Hilti “CP606” for wall mounted situation with the backing materials being the 130 mm deep by 100 kg/m³ mineral wool and 85 mm deep by 140 kg/m³ mineral wool. The width of the mineral wool shall be slightly wider than the gap width such that the installation of the mineral wool shall be conducted by slight compression. The sealant and the backing materials are applied on both sides of the wall, or the backing materials shall be in full depth. Heat exposure may be from either side of the wall:

Table 4.2.3 – The use of Hilti “CP 606” with mineral wool backing in wall mounted situation

Gap width (mm)	Seal Depth (mm)	Gap Faces	Integrity	Insulation
0-15	6	AAC/ACC	240	240
0-30	10	AAC/AAC	240	240
0-15	6	Steel/Steel	240	0
16-20	10	Steel/Steel	240	0
21-30	15	Steel/Steel	240	30
0-15	6	AAC/Steel	240	0
0-30	10	AAC/Steel	240	240

- (d) The application of Hilti “CP606” for wall mounted situation with the backing materials being the PE backer rod with the diameter of the backer rod shall be slightly larger than the gap width as mentioned below, and friction fit into the gap. The sealant and the backing materials are applied on both sides of the wall. Heat exposure may be from either side of the wall:

Table 4.2.4 – The use of Hilti “CP 606” with PE backer rod in wall mounted situation

Gap width (mm)	Seal Depth (mm)	Gap Faces	Integrity	Insulation
0-15	6	AAC/ACC	120	60
0-30	10	AAC/AAC	240	240
0-30	10	AAC/Steel	240	240

Discussion

- (a) For the situation that the linear gap sealing is floor mounted with the mineral wool being the backing materials. This condition of application is basically referenced to the test evidence WARRES 69754/C and the WARRE 71151/B. In the test evidence WARRES 69754/C, specimen "4" demonstrated the ability of the 'CP606' seals to seal up the gap created by the AAC/AAC interface and with a gap width of 30 mm and the applied sealant depth of 15 mm. The sealant was backed by 30 mm by 85 mm deep by 140 kg/m³ mineral wool. In this tested condition, the sealing system achieved the fire resistance performance of 240 minutes integrity and 216 minutes insulation. Based on this, it is reasonable to believe that for the gap reduced in width, a similar or slightly improved performance would be achieved. While for the specimen "1" of the same test evidence, the gap width of 20 mm wide was applied with 10 mm deep Hilti "CP606" sealant backed with PE backer rod. This specimen had achieved the fire resistance performance of 242 minutes integrity and 130 minutes insulation. Since the use of mineral as the backing material shall give a better fire resistance performance, and the results also had no violation to the achieved performance. Based on this, the proposal to use 10 mm deep sealant for a gap width of 20 mm wide is considered acceptable.

In the test evidence WARRES 71151/B, the same situation that the gap was in between the AAC/AAC surfaces but the gap width was 15 mm. The application depth of the Hilti "CP606" sealant was 6 mm and backed with 144 mm deep by 100 kg/m³ mineral wool. The system had achieved the fire resistance performance of 242 minutes integrity and insulation performance.

Based on the above, the appraisal for the use of Hilti "CP606" in between the AAC/AAC liner joint is considered generally supported by direct test evidence.

While in case for the linear joint in between the steel/steel surface, the specimen "3" in the test evidence WARRES 69754/C had demonstrated for the gap width of 30 mm and applied with 15 mm deep Hilti "CP 606" sealant backed with 85 mm deep by 140 kg/m³. This setup had achieved 242 minutes integrity and 36 minutes insulation, which is directly adopted in the Table 4.2.1.

While in case for narrower gap width, the same application depth as in the case of AAC/AAC is considered as acceptable in the case of backed by mineral wool, since the mineral wool shall also aid in maintaining the overall integrity. But in such case, the situations are regarded as demonstrating the integrity performance only.

For the situation that the linear gap is formed by AAC/steel surface, the performance is expected to be in between the scenarios of AAC/AAC and Steel/Steel. As a conservative consideration with no direct test evidence support, this application is adopted as the same as the Steel/Steel situation.

- (b) For the situation that the linear gap sealing is floor mounted with the PE backer rod being the backing materials. This condition of application is referenced to the test evidence WARRES 69754/C. In the test, specimen "1" demonstrated the ability of the 'CP606' sealant to seal up the

gap created by the AAC/AAC interface and with a gap width of 20 mm and the applied sealant depth of 10 mm. The sealant was backed by 24 mm diameter polyethylene foam backer rod. In this tested condition, the sealing system achieved the fire resistance performance of 240 minutes integrity and 130 minutes insulation. Based on the test evidence for the use of Hilti "CP606" as the linear gap sealing, it is discovered that the critical factor in increasing the width of the seal is considered to be the aspect ratio. The tested ratio of the gap width to the applied sealant depth is approximately 2:1. Therefore, the sealant shall be applied with at least this ratio to maintain the achieved fire resistance performance. In case if the gap width is increased up to 30 mm wide, subject to this minimum ratio need to be maintained, the applied sealant depth is therefore at least 15 mm.

It is further proposed that for the gap width reduced to 15 mm wide, the sealant depth of 6 mm is applied but with the expected fire resistance performance is up to 120 minutes integrity and 60 minutes insulation. The proposal using the aspect ratio of slightly smaller than 2:1 as stated above, but the appraised required fire resistance performance is 50% reduced as well. Based on this, it is likely to believe that the expected fire resistance performance is considered as acceptable.

- (c) In the appraisal for the situation that the linear gap sealing is wall mounted with the mineral wool being the backing materials. This condition of application is basically referenced to the test evidence WF146725 Issue 2, WARRES 69754/C and the WARRE 71151/B. In this case, the test evidence of floor mounted situation is taken into consideration as well. Since the floor situation is generally regard as a more onerous situation that the whole seal shall subject to a pressure of approximately 20 Pa, and sealing material will subjected to the gravitational force which may have potential to collapse due to falling. In addition, in case for wall mounted situation, because the heat exposure will be from either side, therefore, the application of the sealant is proposed to be on both sides as well. The provision is a conservative approach with about doubled performance buffer.

Therefore, in this section, the application table is general the same as the Table 4.2.1 for floor mounted application, but only with the two scenarios, the gap width wider than 15 mm up to 30 mm and the linear joint seal is composed by AAC/AAC or AAC/steel facings, the application rate is referenced to the additional test evidence WF 146725 Issue 2. In which the specimen "B" which was the gap width of 30 mm applied with 10 mm deep Hilti "CP606" sealant on both sides of a 150 mm thick wall and the cavity in between fully filled with 96 kg/m³ mineral wool. The gap is created by the AAC/steel facings. In this tested scenario, the sealing system achieved the fire resistance performance of 241 minutes integrity and insulation. Although the test was conducted in accordance with BS EN 1363-1, it had been demonstrated in section 4.1 of this report, the result is applicable for the appraisal against the BS 476-20. With this direct test evidence, the Table 3 is revised that for the gap width up to 30 mm, the application of 10 mm deep sealant on

both sides and fully backed with mineral wool is capable to provide the fire resistance performance of 240 minutes integrity and insulation in both AAC/AAC and AAC/steel situation.

- (d) For the situation that the linear gap sealing is wall mounted with the PE backer rod being the backing materials. Again, this condition of application is basically referenced to the test evidence WF146725 Issue 2, WARRES 69754/C and the WARRE 71151/B. In this case, the test evidence of floor mounted situation is taken into consideration as well. Since the floor situation is generally regard as a more onerous situation that the whole seal shall subject to a pressure of approximately 20 Pa, and sealing material will subjected to the gravitational force which may have potential to collapse due to falling. In addition, in case for wall mounted situation, because the heat exposure will be from either side, therefore, the application of the sealant is proposed to be on both sides as well. The provision is a conservative approach with about doubled performance buffer.

In this section, the specimen "A" in the test evidence WF 146725 Issue 2 gave supplement test result for the application of Hilti "CP606" sealant to 30 mm wide gap and 10 mm deep on both sides of the wall (AAC/Steel) interface, and backed with PE backer rod on each side as well. The system had achieved 241 minutes integrity and insulation performance. This test result revised the application of the sealant for gap width up to 30 mm as given in Table 4.2.4.

In summary, the proposed application conditions of the Hilti "CP606" as given in Tables 4.2.1 to 4.2.4 are generally referenced to the tested condition, with some of them are appraised with a conservative approach.

4.3 The fire resistance performance of linear joint sealing system using the Hilti “CP601S” with respect to BS 476: Part 20: 1987.

Proposal

It is proposed that Hilti ‘CP 601S’ may be used for the purpose of linear gap sealing under either the wall mounted or floor mounted situation with the substrate of the linear gap may be of different materials. The installation of the sealant may be backed by rockwool or PE rod. The scope below described the condition of seal application at different scenarios and the outcome fire resistance performance for each specific scenario with respect to BS 476: Part 20: 1987.

- (a) The application of Hilti “CP601S” for floor mounted situation with the backing materials being the 130 mm deep by 100 kg/m³ mineral wool and 85 mm deep by 140 kg/m³ mineral wool. The width of the mineral wool shall be slightly wider than the gap width such that the installation of the mineral wool shall be conducted by slight compression. The sealant and the backing materials are applied on the unexposed side only with the heat exposure from underside of the floor only:

Table 4.3.1 – The use of Hilti “CP 601S” with rockwool backing in floor mounted situation

Gap width (mm)	Seal Depth (mm)	Gap Faces	Integrity	Insulation
0-15	6	AAC/AAC	240	240
16-100	15	AAC/AAC	240	240
0-30	15	Steel/Steel	60	0
0-30	15	AAC/Steel	120	0

- (b) The application of Hilti “CP601S” for floor mounted situation with the backing materials being the PE backer rod with the diameter of the backer rod shall be slightly larger than the gap width as mentioned below, and friction fit into the gap. The sealant and the backing materials are applied on the unexposed side only with the heat exposure from underside of the floor only:

Table 4.3.2 – The use of Hilti “CP 601S” with PE backer rod in floor mounted situation

Gap width (mm)	Seal Depth (mm)	Gap Faces	Integrity	Insulation
0-10	6	AAC/AAC	120	60
11-30	15	AAC/AAC	240	120
11-50@	20@	AAC/AAC	240	240

Note@: Applicable only if the sealant backed with PE backer rod apply on both sides of floor

- (c) The application of Hilti “CP601S” for wall mounted situation with the backing materials being the 130 mm deep by 100 kg/m³ mineral wool and 85 mm deep by 140 kg/m³ mineral wool. The width of the mineral wool shall be slightly wider than the gap width such that the installation of the mineral wool shall be conducted by slight compression. The sealant and the backing materials are applied on both sides of the wall, or the backing materials shall be in full depth. Heat exposure may be from either side of the wall:

Table 4.3.3 – The use of Hilti “CP 601S” with mineral wool backing in wall mounted situation

Gap width (mm)	Seal Depth (mm)	Gap Faces	Integrity	Insulation
0-15	6	AAC/ACC	240	240
16-100	15	AAC/AAC	240	240
0-30	15	Steel/Steel	60	0
0-30	15	AAC/Steel	120	0

- (d) The application of Hilti “CP601S” for wall mounted situation with the backing materials being the PE backer rod with the diameter of the backer rod shall be slightly larger than the gap width as mentioned below and friction fit into the gap. The sealant and the backing materials are applied on both sides of the wall. Heat exposure may be from either side of the wall:

Table 4.3.4 – The use of Hilti “CP 601S” with PE backer rod in wall mounted situation

Gap width (mm)	Seal Depth (mm)	Gap Faces	Integrity	Insulation
0-10	6	AAC/ACC	240	240
11-30	15	AAC/AAC	240	120
11-50	20	AAC/Steel	240	240

Discussion

(a) For the situation that the linear gap sealing is floor mounted with the mineral wool being the backing materials. This condition of application is basically referenced to the test evidence WARRE 71151/B and WF 146563. In the test evidence WARRES 71151/B, the specimens "H2", "H3" and "H4" demonstrated the ability of the 'CP601S' sealant to seal up the gap created by the AAC/AAC interface and with a gap width of 15 mm applied with 6 mm deep sealant and the 30 and 100 mm wide gaps applied with 15 mm deep sealant. The sealant was backed by approximately 130 mm deep by 100 kg/m³ mineral wool. In this tested condition, the sealing system achieved the fire resistance performance of 242 minutes integrity and insulation. Based on this, it is reasonable to believe that for the gap reduced in width, a similar or slightly improved performance would be achieved. Based on this the application conditions for the AAC/AAC linear joint are worked out.

In case for the Steel/Steel and AAC/Steel application, the secondary test evidence SP test report 97R1 3024C is referenced. This is the test conducted in accordance with SIS 02 48 20, edition 2, which is a similar fire resistance test compared to the BS 476-20. Since the achieved fire resistance performance is generally consistent with the test results obtained from other BS 476-20 test. Therefore, the use of this test report as secondary test evidence to support the use of the Hilti "CP601S" is considered as adequate. In this test, the linear joints "11" is the application of Hilti "CP601S" to Concrete/Steel interface with the gap width of 30 mm applied with 15 mm deep sealant and backed with 120 mm deep by 45 kg/m³ mineral wool. This system achieved 120 minutes integrity and 24 minutes insulation. While in the proposed application, the backing mineral wool is 130 mm deep by 100 kg/m³ or 85 mm deep by 140 kg/m³ which are both massive than that tested. The proposed application condition is therefore acceptable.

For in the test with linear joint referenced "13", it is the application of Hilti "CP601S" to Steel/Steel interface with the gap width of 30 mm applied with 15 mm deep sealant and backed with 120 mm deep by 45 kg/m³ mineral wool. This system achieved 82 minutes integrity and 24 minutes insulation. While in the proposed application, the backing mineral wool is 130 mm deep by 100 kg/m³ or 85 mm deep by 140 kg/m³ which are both massive than that tested. The proposed application condition is therefore acceptable.

In the test evidence WARRES 71151/B, the same situation that the gap was in between the AAC/AAC surfaces but the gap width was 15 mm. The application depth of the Hilti "CP606" sealant was 6 mm and backed with 144 mm deep by 100 kg/m³ mineral wool. The system had achieved the fire resistance performance of 242 minutes integrity and insulation performance. Based on the above, the appraisal for the use of Hilti "CP606" in between the AAC/AAC liner joint is considered generally supported by direct test evidence.

While in case for the linear joint in between the steel/steel surface, the specimen "3" in the test evidence WARRES 69754/C had demonstrated for the gap width of 30 mm and applied with 15 mm deep Hilti "CP 606" sealant backed with 85 mm deep by 140 kg/m³. This setup had achieved 242 minutes integrity and 36 minutes insulation, which is directly adopted in the Table 1. While in case for narrower gap width, the same application depth as in the case of AAC/AAC is considered as acceptable in the case of backed by mineral wool, since the mineral wool shall also aid in maintaining the overall integrity. But in such case, the situations are regarded as demonstrating the integrity performance only.

For the situation that the linear gap is formed by AAC/steel surface, the performance is expected to be in between the scenarios of AAC/AAC and Steel/Steel. As a conservative consideration with no direct test evidence support, this application is adopted as the same as the Steel/Steel situation.

- (b) For the situation that the linear gap sealing is floor mounted with the PE backer rod being the backing materials. This condition of application is referenced to the test evidence WF146563. In the test, specimens "E", "F", "G" and "H" demonstrated the ability of the 'CP601S' sealant to seal up the gap created by the AAC/AAC interface. Specimens "G" and "H" are the linear joint with gap width of 30 mm and 10 mm and applied with sealant depth 15 mm and 6 mm, respectively. The sealant was backed by 35 mm diameter and 15 mm diameter backer rod. In these tested conditions, the sealing system achieved the fire resistance performance of 240 minutes integrity and 126 minutes insulation for gap width of 30 mm and 240 minutes integrity and insulation for the gap width of 10 mm. In the situation that the gap width increased to 50 mm wide, applied with 20 mm deep sealant and 50 mm PE rod on both sides of the floor had achieved 240 minutes integrity and insulation performance as supported by specimen "E" in the test.
- (c) In the appraisal for the situation that the linear gap sealing is wall mounted with the mineral wool being the backing materials. This condition of application is basically referenced to the situation of floor mounted case. Since the floor situation is generally regard as a more onerous situation that the whole seal shall subject to a pressure of approximately 20 Pa, and sealing material will subjected to the gravitational force which may have potential to collapse due to falling. In addition, in case for wall mounted situation, because the heat exposure will be from either side, therefore, the application of the sealant is proposed to be on both sides as well. The provision is a conservative approach with about doubled performance buffer.
- Therefore, in this section, the application table is general the same as the Table 4.3.1 for floor mounted application
- (d) For the situation that the linear gap sealing is wall mounted with the PE backer rod being the backing materials. Again, this condition of application is basically similar to the floor mounted

situation. Since the floor situation is generally regard as a more onerous situation that the whole seal shall subject to a pressure of approximately 20 Pa, and sealing material will subjected to the gravitational force which maya have potential to collapse due to falling. In addition, in case for wall mounted situation, because the heat exposure will be from either side, therefore, the application of the sealant is proposed to be on both sides as well. The provision is a conservative approach with about doubled performance buffer.

In summary, the proposed application conditions of the Hilti "CP601S" as given in Tables 4.3.1 to 4.3.4 are generally referenced to the tested condition, with some of them are appraised with a conservative approach.

5 CONCLUSION

The proposed use of Hilti "CP606" and "CP601S" for the linear joint seal in both floor mounted and wall mounted as discussed in Section 4 of this report, are capable to maintain the fire resistance performance of up to 240 minutes integrity and various insulation performance with respect to BS 476: Part 20: 1987.

6 DECLARATION BY APPLICANT

We, Hilti (Hong Kong) Limited, confirm that the material, component or element of structure, which is the subject of the test report being reviewed, has not to our knowledge been subjected to another test to the standard against which the assessment is being made.

We agree to withdraw this assessment from circulation should the component or element of structure be the subject of another test to the standard against which the assessment is being made.

We are not aware of any information that could affect the conclusions of this assessment.

If we subsequently become aware of any such information we agree to ask the assessing authority to withdraw the assessment.

7 VALIDITY

This assessment is based on test data, experience and the information supplied. The assessment will be invalidated if the assessed construction is subsequently tested since actual test data is deemed to take precedence over an expressed opinion. Any changes in the specification of product will invalidate this assessment. This assessment relates only to the specimen assessed and does not by itself infer that the product is approved under any other endorsements, approval or certification scheme. Since the appraisal method is under development, the laboratory reserved the right to supersede this assessment in case the appraisal method had been changed.

This report only relates to the specimen(s) tested and may only be reproduced by the sponsor in full, without comment, abridgement and modifications.

8 SIGNATORIES

Assessment by:

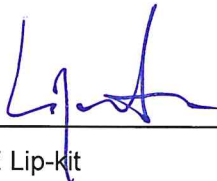

Dr. SZE Lip-kit

Test Consultant

Research Engineering Development

Façade Consultants Limited

Reviewed by:



Ir Dr. YUEN Sai-wing, MHKIE (Fire)

Authorized Signature

Research Engineering Development

Façade Consultants Limited

APPENDIX A – SUMMARY OF APPLICATION OF SEALANTS IN DIFFERENT SCENARIOS

Table A.1: Application of sealants in floor mount situation

Sealant	Gap width (mm)	Seal Depth (mm)	Gap Faces	Backing Materials*	Integrity	Insulation
CP 601S	0-15	6	AAC/AAC	mineral wool	240	240
	16-100	15	AAC/AAC	mineral wool	240	240
	0-30	15	Steel/Steel	mineral wool	60	0
	0-30	15	AAC/Steel	mineral wool	120	0
	0-10	6	AAC/AAC	PE rod	120	60
	11-30	15	AAC/AAC	PE rod	240	120
	11-50@	20@	AAC/AAC	PE rod	240	240
CP 606	0-15	6	AAC/AAC	mineral wool	240	240
	16-20	10	AAC/AAC	mineral wool	240	120
	21-30	15	AAC/AAC	mineral wool	240	180
	0-15	6	Steel/Steel	mineral wool	240	0
	16-20	10	Steel/Steel	mineral wool	240	0
	21-30	15	Steel/Steel	mineral wool	240	30
	0-15	6	AAC/Steel	mineral wool	240	0
	16-20	10	AAC/Steel	mineral wool	240	0
	21-30	15	AAC/Steel	mineral wool	240	30
	0-15	6	AAC/AAC	PE rod	120	60
	0-20	10	AAC/AAC	PE rod	240	120
	21-30	15	AAC/AAC	PE rod	240	120

Note@: Applicable only if the sealant backed with PE backer rod apply on both sides of floor

Note*: For mineral wool as backing material, 130 mm deep by 100 kg/m³ mineral wool or 85 mm deep by 140 kg/m³ mineral wool

Table A.2: Application of sealants in wall mount situation

Sealant	Gap width (mm)	Seal Depth (mm)	Gap Faces	Backing Materials*	Integrity	Insulation
CP 601S	0-15	6	AAC/ACC	mineral wool	240	240
	16-100	15	AAC/AAC	mineral wool	240	240
	0-30	15	Steel/Steel	mineral wool	60	0
	0-30	15	AAC/Steel	mineral wool	120	0
	0-10	6	AAC/ACC	PE rod	240	240
	11-30	15	AAC/AAC	PE rod	240	120
	11-30	20	AAC/Steel	PE rod	240	240
CP 606	0-15	6	AAC/ACC	mineral wool	240	240
	0-30	10	AAC/AAC	mineral wool	240	240
	0-15	6	Steel/Steel	mineral wool	240	0
	16-20	10	Steel/Steel	mineral wool	240	0
	21-30	15	Steel/Steel	mineral wool	240	30
	0-15	6	AAC/Steel	mineral wool	240	0
	0-30	10	AAC/Steel	mineral wool	240	240
	0-15	6	AAC/ACC	PE rod	120	60
	0-30	10	AAC/AAC	PE rod	240	240
	0-30	10	AAC/Steel	PE rod	240	240

Note*: For mineral wool as backing material, 130 mm deep by 100 kg/m³ mineral wool or 85 mm deep by 140 kg/m³ mineral wool

- End of Report -

ASSESSMENT REPORT

The Fire Resistance Performance of Hilti Pipe Penetration Sealing Systems

Report No.: R23A14-1A
Issue Date: 13 February, 2023
Date of Review: 12 February, 2026

Report Sponsor

Hilti (Hong Kong) Limited
701-704 & 708B, Tower A Manulife Finance Centre,
223 Wai Yip Street, Kwun Tong, Kowloon, HK

This report only relates to the specimen(s) tested and may only be reproduced by the sponsor in full, without comment, abridgement and modifications.

CONTENT

Section	Description	Page
1	INTRODUCTION	3
2	ASSUMPTIONS	3
3	SUPPORTING DATA	4
4	PROPOSAL & DISCUSSION	14
5	CONCLUSION	19
6	DECLARATION BY APPLICANT	19
7	VALIDITY	19
8	SIGNATORIES	19
APPENDIX A – SUMMARY OF APPLICATION OF SEALANTS IN DIFFERENT SCENARIOS		20

REVISION HISTORY

Issue date (DD/MM/YYYY)	Issue number	Remark
13/02/2023	0	Initial version

THE FIRE RESISTANCE PERFORMANCE OF PIPE PENETRATION SYSTEMS

1 INTRODUCTION

This assessment report presents an appraisal for the use of the Hilti “CP606” and “CP601S” for pipe penetration sealing purpose in either floor mounted or wall mounted situation. The appraisal will be based on the test evidence as shown in section 3 of this report. This report is prepared for Hilti (Hong Kong) Limited of 701-704 & 708B, Tower A, Manulife Finance Centre, 223 Wai Yip Street, Kwun Tong, Kowloon, HK.

The proposed sealing for the pipe penetration system are required to provide a fire resistance performance of up to 240 minutes integrity performance with respect to BS 476: Part 20: 1987.

2 ASSUMPTIONS

The proposed systems are assumed to be installed in a similar manner to that of the previously tested system by competent installers. It is assumed that the modified systems will be constructed in a similar manner from materials and components of the same manufacture and equivalent quality as tested with supporting test evidence or otherwise appraised by RED. Further assumptions related to the specific modifications will be stated in the report.

It is also assumed that the supporting structures to which the perimeter of the systems will be fixed are capable of supporting the proposed structure effectively.

Assuming that the issue of the original test report is valid, the current testing standard or testing experience has not been changed and the procedures adopted for the original report have been re-examined and reviewed that there have been no changes to the specification of the construction considered in the original report. If contradictory data or any related evidence becomes available to RED, the assessment will be unconditionally withdrawn and the sponsor will be notified. This report is based on the given information, in which is declared by report sponsor that no contradictory data has become available.

3 SUPPORTING DATA

3.1 Summary of Supporting Test Evidence

Report no.	Sections	Description
Primary Test Evidence		
WARRES report no. 101295/A	4.2	Supporting indicative test evidence for the use of the Hilti "CP606" and "CP601S" for the metal pipe penetration sealing purpose. Both wall mounted and floor mounted situation were considered. With the test was conducted in accordance with BS 476: Part 20: 1987.
WF report no. 146725 Issue 2	4.1 - 4.2	Supporting test evidence for the use of the Hilti "CP606" sealant for the purpose of sealing wall mounted linear gap joint. The test was conducted in accordance with BS EN 1363-1.
WARRES report no. 69754/C	4.2	Supporting test evidence for the use of the Hilti "CP606" sealant for the purpose of sealing floor mounted linear gap joint. The test was conducted in accordance with BS 476: Part 20.
WARRES report no. 71151/A	4.2	Supporting test evidence for the use of the Hilti "CP606" sealant for the purpose of sealing wall mounted linear gap joint. The test was conducted in accordance with BS 476: Part 20.
WARRES report no. 71151/B	4.2	Supporting test evidence for the use of the Hilti "CP606" and "CP601S" sealant for the purpose of sealing floor mounted linear gap joint. The test was conducted in accordance with BS 476: Part 20.
WF report no. 143653	4.2	Supporting test evidence for the use of the Hilti "CP601S" sealant for the purpose of sealing wall or floor mounted linear gap joint. The test was conducted in accordance with BS 476: Part 20.
RED report no. R18G14-2A	4.2	Supporting test evidence for the use of CP606 backed with CF-F 750 for wall mounted situation. The test was conducted in accordance with BS 476: Part 20.

Secondary Test Evidence		
97R1 3024C	4.2	Supporting test evidence for the use of the Hilti "CP606" and "CP601S" sealant for the purpose of sealing wall mounted linear gap joint. The test was conducted in accordance with ISO 834.

3.2 Primary Test Evidence

3.2.1 Warringtonfire Test Report No. 101295/A*

A fire resistance test stated to be in accordance with BS 476: Part 20 1987 with additional guideline from prEN 1366-3:1993 to evaluate the fire resistance performance of four specimens of copper pipe penetration sealing systems through AAC wall or floor constructions (referenced A, D, F and G) was performed by the Warringtonfire testing laboratory on 12th January, 1998. The report was prepared for Hilti Ag, the Hilti Entwicklungsgesellschaft mbH had given permission to use this data.

The section of wall was of 100 mm thickness and the section of floor was of 150 mm thickness. Each was provided with two (2) 127 mm diameter apertures penetrated by a copper pipe of 42 mm outside diameter and 1.25 mm thick. The specimens penetrating the wall were the specimens A and D, those penetrating the floor were the specimens F and G. The area around the pipe was infilled with a mastic sealant backed with rock fibre insulation. The rock fibre was 60 mm thick by 100 kg/m³ in wall situation and 100 mm thick by 100 kg/m³ in floor situation. The sealants that used in the test were CP601S in specimens D and F and CP606 in specimens A and G, respectively.

The specimens satisfied the performance requirements specified in BS 476: Part 20: 1987 for the following periods:

Wall mounted seals			
	Type of seal	Integrity (minutes)	Insulation (minutes)
Specimen 'A'	CP606	241	10
Specimen 'D'	CP601S	157	12
Floor mounted seals			
	Type of seal	Integrity (minutes)	Insulation (minutes)
Specimen 'F'	CP601S	240	12
Specimen 'G'	CP606	240	12

The test was discontinued after a heating period of 240 minutes (See WARRES report no. C101295/A for full details).

*Note: the test data is more than five years old; we have reviewed this data against the current test procedures as per BS 476: Part 20 and found it suitable for this assessment.

3.2.2 Warringtonfire Test Report No. 146725 Issue 2#

A fire resistance test in accordance with BS EN 1366-3: 2004 and utilising the general principles of BS EN 1363-1: 1999 to evaluate the fire resistance performance of eighteen specimens of penetration sealing systems (referenced 1 to 18), and three linear gap sealing systems (referenced A to C) was performed by the Warringtonfire testing laboratory on 15th July, 2005. The report was prepared for Hilti (Great Britain) Limited, the Hilti Entwicklungsgesellschaft mbH had given permission to use this data.

In this assessment report, only the specimens "A" to "C" were considered.

In this test, specimens "A" and "B" were vertically orientated liner gap seals had nominal sizes of 1,000 mm by 30 mm and incorporated a galvanised mild steel angle fitted to one face. Specimen A was sealed on each face with "CP 606" and a Polyethylene backing rod. Specimen "B" was infilled with mineral wool and sealed on each face with "CP606".

Specimen C had overall nominal dimensions of 1,000 mm by 50 mm and incorporated a galvanised mild steel angle on its lower face. The gap was sealed on its exposed face with "CP606" and two Polyethylene backing rods.

The specimens satisfied the performance requirements specified in BS EN 1363-1 and BS EN 1366-3 for the following periods:

Specimen 'A'

Integrity: 241 Minutes (No failure)

Insulation: 106 Minutes

Specimen 'B'

Integrity: 241 Minutes (No failure)

Insulation: 100 Minutes

Specimen 'C'

Integrity: 40 Minutes

Insulation: 8 Minutes

The test was discontinued after a heating period of 241 minutes (See WF report no. 146725 Issue 2 for full details).

#Note: the test data is more than five years old; we have reviewed this data against the current test procedures as per BS EN 1363-1: 1999 and found it suitable for this assessment.

3.2.3 WARRES Test Report No. 69754/C*

A fire resistance test on four specimens of proprietary gap sealing systems incorporated between various floor sections used the general principles of BS 476: Part 20: 1987 and in conjunction with additional guidelines from the draft document CENT/TC127 N579 was performed at the WARRES laboratory on 14th November 1996. The test sponsor was Hilt Ag, the Hilti Entwicklungsgesellschaft mbH had given permission to use this data.

The test was performed on four different specimens of gap sealing systems referenced 1 to 4 for the purposes of the test. Three specimens were incorporated between aerated concrete gap faces, the fourth between steel gap faces. The gap referenced 1 and 2 were of nominal width 20 mm, those referenced 3 and 4 were of nominal width of 30 mm, all were of nominal length 950 mm. Each gap was sealed using Hilti CP606 in conjunction with a proprietary backing material.

The performance of each specimen assessed against the integrity and insulation (maximum temperature rise) criteria of BS 476: Part 20: 1987, the results were expressed as follow:

Specimen Ref:	Gap Width (mm)	Gap Faces	CP606 Depth	Backing Material	Integrity (Min)	Insulation (Min)
1	20	AAC/AAC	10	PE	240	130
2	20	AAC/AAC	15	CF 125-50	240	208
3	30	Steel/Steel	15	Rockfibre	240	36
4	30	AAC/AAC	15	Rockfibre	240	216

The test was discontinued after a period of 240 minutes (See WARRES no. 69754/C for full details).

*Note: the test data is more than five years old; we have reviewed this data against the current test procedures as per BS 476: Part 20: 1987 and found it suitable for this assessment.

3.2.4 WARRES Test Report No. 71151/A*

A fire resistance test stated to be in accordance with BS 476: Part 20: 1987 on five different specimens of proprietary gap sealing system was performance by the Warringtonfire testing laboratory on 25th April, 1997. The report was prepared for Hilti GmbH, the Hilti Entwicklungsgesellschaft mbH had given permission to use this data.

The specimens were referenced "V1" to "V5" for the purpose of the test. Specimens "V1" and "V2" were comprised of an 80 mm deep layer of Rockfibre faced on both sides with a layer of 10 mm thick 'Hilti CP606'. The specimens were installed in a nominally 65 mm high gap between a simulated partition wall head and a steel composite deck above.

Specimen "V3" was comprised of a 90 mm deep layer of rockfibre faced on both sides with a layer of 5 mm thick 'Hilti CP606'. The specimen was installed in a nominally 65 mm high gap between a simulated partition wall head and a steel composite deck above.

Specimens "V4" and "V5" were comprised a gap seal for use at a partition wall fixed edge detail. Specimen "V4" consisted of a 25 mm deep by 10 mm wide aperture at both sides infilled with a 15 mm deep layer of rockfibre and faced with a layer of 10 mm thick 'Hilti CP606'. Specimen "V5" consisted of a 25 mm deep by 5 mm wide aperture at both sides infilled with a 20 mm deep layer of rock fibre and faced with a layer of 5 mm thick 'Hilti CP 606'.

The specimen satisfied the performance requirements specified in BS 476: Part 20: 1987 for the following periods:

Specimen ref:	Integrity (mins)	Insulation (mins)
V1	136	136
V2	136	136
V3	136	135
V4	136	136
V5	136	136

The test was discontinued after a heating period of 242 minutes (See WARRES test report no. 71151/A for full details).

*Note: The test data is more than five years old; we have reviewed this data against the current test procedures as per BS 476: Part 20: 1987 and found it suitable for this assessment.

@Note: The test include the horizontally mounted specimen at the same time, after 136 minutes, the specimens "V1" to V3" were covered with a layer of ceramic fibre in order to allow the test to continue for the horizontally mounted specimens.

3.2.5 WARRES Test Report No. 71151/B*

A fire resistance test stated to be in accordance with BS 476: Part 20: 1987 on four different specimens of proprietary gap sealing system was performance by the Warringtonfire testing laboratory on 25th April, 1997. The report was prepared for Hilti GmbH, the Hilti Entwicklungsgesellschaft mbH had given permission to use this data.

The specimens were referenced "H1" to "H4" for the purpose of the test. The specimens were incorporated between aerated concrete gap faces. The gaps were of nominal length 900 mm, and were sealed using Hilti CP 606 or CP 601S in conjunction with a rockfibre backing material.

The specimen "H1" was a 15 mm wide linear gap sealed with 6 mm thick Hilti "CP606" backed with rockfibre. The specimen "H2" was a 15 mm wide linear gap sealed with 6 mm thick Hilti "CP601S" backed with rockfibre. The specimen "H3" was a 30 mm wide linear gap sealed with 15 mm thick Hilti "CP601S" backed with rockfibre. The specimen "H4" was a 100 mm wide linear gap sealed with 15 mm thick Hilti "CP601S" backed with rockfibre.

The specimen satisfied the performance requirements specified in BS 476: Part 20: 1987 for the following periods:

Specimen ref:	Integrity (mins)	Insulation (mins)
H1	242	242
H2	242	242
H3	242	242
H4	242	242

The test was discontinued after a heating period of 242 minutes (See WARRES test report no. 71151/B for full details).

*Note: The test data is more than five years old; we have reviewed this data against the current test procedures as per BS 476: Part 20: 1987 and found it suitable for this assessment.

3.2.6 Warringtonfire Test Report No. 143653*

A fire resistance test in accordance with BS 476: Part 20: 1987 to evaluate the fire resistance performance of eight specimens of Hilti “CP601S” linear gap sealing systems (referenced A to H) was performed by the Warringtonfire testing laboratory on 20th December, 2004. The report was prepared for Hilti Entwicklung Befestigungstechnik GmbH, the Hilti Entwicklungsgesellschaft mbH had given permission to use this data.

In this test, specimens “A” to “D” were wall mounted specimens whilst the specimens “E” to “H” were floor mounted specimens.

Specimen “A” was a 50 mm gap width, sealed to both the unexposed face and exposed face with Hilti “CP601S” to a depth of 20 mm, backed with two 50 mm diameter backing rods.

Specimen “B” was a 10 mm gap width, sealed to both the unexposed face and exposed face with Hilti “CP601S” to a depth of 6 mm, backed with two 15 mm diameter backing rods.

Specimen “C” was a 30 mm gap width, sealed to the unexposed face with Hilti “CP601S” to a depth of 15 mm, backed with one 35 mm diameter backing rods.

Specimen “D” was a 10 mm gap width, sealed to the unexposed face with Hilti “CP601S” to a depth of 6 mm, backed with one 15 mm diameter backing rods.

Specimen “E” was a 50 mm gap width, sealed to both the unexposed face and exposed face with Hilti “CP601S” to a depth of 20 mm, backed with two 50 mm diameter backing rods.

Specimen “F” was a 10 mm gap width, sealed to both the unexposed face and exposed face with Hilti “CP601S” to a depth of 6 mm, backed with two 15 mm diameter backing rods.

Specimen “G” was a 30 mm gap width, sealed to the unexposed face with Hilti “CP601S” to a depth of 15 mm, backed with one 35 mm diameter backing rods.

Specimen “H” was a 10 mm gap width, sealed to the unexposed face with Hilti “CP601S” to a depth of 6 mm, backed with one 15 mm diameter backing rods.

The specimens satisfied the performance requirements specified in BS EN 1363-1 and BS EN 1366-3 for the following periods:

Specimen ref:	Integrity (mins)	Insulation (mins)	Specimen ref:	Integrity (mins)	Insulation (mins)
A	240	240	E	240	240
B	240	240	F	240	240
C	240	96	G	240	126
D	240	240	H	240	240

The test was discontinued after a heating period of 240 minutes (See WF report no. 143653 for full details).

*Note: the test data is more than five years old; we have reviewed this data against the current test procedures as per BS 476: Part 20: 1987 and found it suitable for this assessment.

3.2.7 RED Test Report No. R18G24-2A

A fire resistance test in accordance with BS 476: Part 20: 1987 to evaluate the fire resistance performance of nine different specimens of Hilti sealing systems (referenced '12', '13', '14', '15', '16', '17', '18', '19' and '20') was performed by the RED testing laboratory on 28th September, 2018. The report was prepared for Hilti (Hong Kong) Limited.

In this test, only specimen "19" was considered. Specimen '19' had overall dimensions of 160 mm diameter by 1,200 mm long. It was comprised of a G.M.S. pipe with sizes of 138 mm inner diameter by 1.5 mm thick. The gaps between the pipe and concrete wall were applied with 'Hilti CP606' sealant and 'Hilti CF-F 750' filling foam. The penetrated pipes were supported by fixed to 40 mm by 20 mm by 3 mm thick steel L-angles, located at 100 mm from the concrete wall on both sides. The steel angles were supported by 2 nos. of M10 steel rods to the concrete lining. The opening was covered by nominal 40 mm thick rockwool with density 160 kg/m³.

The specimens satisfied the performance requirements specified in BS 476: Part 20: 1987 for the following periods:

	Integrity	Insulation
Specimen '19'	242 Minutes (No failure)	242 Minutes

The test was discontinued after a heating period of 242 minutes (See RED report no. R18G14-2A for full details).

3.3 Secondary Test Evidence

3.3.1 SP Test Report No. 97R1 3024C[^]

A fire resistance test in accordance with SIS 02 48 20, edition 2 to evaluate the fire resistance performance of the linear gap sealing systems was performed by the SP testing laboratory on 20th November, 1997. The report was prepared for Hilti Svenska AB, the Hilti Entwicklungsgesellschaft mbH had given permission to use this data.

The test described various cable services penetrations sealing, cable penetration sealing systems, pipe service penetrations and linear joint sealing systems. In this appraisal, only the linear joint sealing systems using the "CP601S", reference Joint "11" and "13" were considered.

Joint 11 was the linear gap created to simulate the AAC/Steel interface at the joint. The gap width is 30 mm and applied with 15 mm deep Hilti "CP601S" sealant backed with rockfibre material.

Joint 13 was the linear gap created to simulate Steel/Steel interface at the joint. The gap width is 30 mm and applied with 15 mm deep Hilti "CP601S" sealant backed with rockfibre material.

The specimens satisfied the performance requirements specified in the SIS 02 48 20, edition 2 for the following periods:

Joint '11'

Integrity: 126 Minutes (No failure)
Insulation: 24 Minutes

Joint '13'

Integrity: 82 Minutes (No failure)
Insulation: 24 Minutes

The test was discontinued after a heating period of 126 minutes (See SP report no. 97R1 3024C for full details).

[^]Note: the test standard SIS 02 48 20 edition 2, was a test standard with the heating and pressure conditions are identical to those specified in BS 476: Part 20: 1987. The test data is therefore considered as acceptable to be used as the secondary test evidence for the use of Hilti CP 601S sealant.

4 PROPOSAL & DISCUSSION

4.1 *The use of test evidence, which were tested in accordance with BS EN 1363-1: 1999, for the assessment of linear joint sealing system to BS 476: Part 20: 1987*

Proposal

It is proposed that the test evidence of WF report no. 146725 Issue 2 for the linear joint seal system, which were tested in accordance with BS EN 1363-1: 1999, is suitable for use in the assessment against BS 476: Part 20: 1987.

Discussion

The fire test on the linear joint seal systems as tested and described in the above test evidence were carried out in accordance with BS EN 1363-1: 1999. In reviewing the tests, we have considered the design and installation of the specimens, the surrounding construction, the initial furnace temperature, the pressure in the furnace, the changes in the integrity criteria and the behaviour of the fire tests, it is expected that if these fire tests had been conducted in accordance with BS 476: Part 20: 1987 very similar results would have been achieved.

Fire tests to BS EN 1363-1: 1999 and BS 476: Part 20: 1987 have the same furnace temperature-time curve, i.e., the standard ISO temperature time curve represented by $T = 345 \log_{10}(8t + 1) + 20$, where T is the furnace temperature rise and t is the time of heating conditions. However, a more severe overpressure requirement of 5 Pa required by BS EN 1363-1: 1999 was used, which was normally deemed to be more onerous. The passing criteria for the standards of BS EN 1363-1: 1999 and BS 476: Part 20: 1987 are summarised as follows:

Integrity. Monitor the unexposed face of the specimen for evaluation of integrity. A failure of the test construction to maintain integrity occurs when collapse or sustained flaming on the unexposed face occurs or impermeability is exceeded.

Insulation. Failure occurs when (a) the mean unexposed face temperature increases by more than 140 °C above its initial value; or (b) the temperature recorded at any position on the unexposed face is in excess of 180 °C above its initial value; or (c) when integrity failure occurs.

Having stated these criteria, there is no significant difference between the tests to BS EN and British standards. Since the integrity and insulation criteria of BS EN 1363-1: 1999 are basically the same, we can conservatively conclude that the linear joint sealing system as tested and described in WF report no. 146725 Issue 2 will achieve fire resistance performance not worse than tested if test to BS 476: Part 20: 1987.

4.2 The fire resistance performance of copper or steel pipe penetration sealing system using the Hilti “CP606” with respect to BS 476: Part 20: 1987.

Proposal

It is proposed that Hilti ‘CP 606’ and ‘CP601S’ may be used for the purpose of sealing the penetration annular gap in between the metal pipe and the surrounding masonry supporting construction when the pipe penetrating through. The penetration sealing may be modified as stated below:

- (a) The proposed penetration sealing systems applies to both copper and steel pipe penetration situation with the steel pipe diameter may be up to 200 mm, while the copper pipe diameter is up to 50 mm or 200 mm depends on the required fire resistance performance and the wall thickness increased up to 10 mm;
- (b) The annual gaps at the pipe penetration may be maximum 42 mm wide or narrower;
- (c) The condition of penetration sealing using either CP606 or CP601S for various type of pipe, pipe diameter, pipe wall thickness, depth of sealant to be applied, the conditions of backing mineral wool and the expected fire resistance performance are as given in the tables below;
- (d) The condition of penetration sealing using the CP 606 backed with Hilti CF-F 750 filling foam may be used, but the pipe diameter may be up to 50 mm for copper pipe and up to 140 mm for steel pipe. Also the width of annular gap need to reduce to 10 mm.

Table 4.2.1 – The use of Hilti “CP 606” or “CP601S with rockwool backing for metal pipe penetration sealing purpose in wall mount situation:

Service pipe	Maximum pipe diameter	Pipe wall thickness	Seal configuration	Integrity
Wall mount situation				
Copper pipe & steel pipe	200 mm	1.25 to 10 mm	15 mm depth CP606 on both ends with backing of min. 60 mm depth by 100 kg/m ³ mineral wool	120 mins
Copper pipe & steel pipe	200 mm	1.25 to 10 mm	15 mm depth CP601S on both ends with backing of min. 60 mm depth by 100 kg/m ³ mineral wool	120 mins
Copper Pipe	50 mm	1.25 to 10 mm	15 mm depth CP606 on both ends with backing of min. 60 mm depth by 100 kg/m ³ mineral wool	240 mins
Steel pipe	200 mm	1.25 to 10 mm	15 mm depth CP606 on both ends with backing of min. 60 mm depth by 100 kg/m ³ mineral wool	240 mins
Copper pipe	50 mm	1.25 to 10 mm	15 mm depth CP601S on both ends with backing of min. 100 mm depth by 100 kg/m ³ mineral wool	240 mins

Steel pipe	200 mm	1.25 to 10 mm	15 mm depth CP601S on both ends with backing of min. 60 mm depth by 100 kg/m ³ mineral wool	240 mins
Copper pipe	50 mm	1.25 to 10 mm	10 mm depth CP606 on both ends with backing of min. 130 mm or full depth of Hilti 'CF-F 750 filling foam	240 mins
Steel pipe	140 mm	1.25 to 10 mm	10 mm depth CP606 on both ends with backing of min. 130 mm or full depth of Hilti 'CF-F 750 filling foam	240 mins

Table 4.2.2 – The use of Hilti “CP 606” or “CP601S with rockwool backing for metal pipe penetration sealing purpose in floor mount situation:

Service pipe	Maximum pipe diameter	Pipe wall thickness	Seal configuration	Integrity
Floor mount situation				
Copper pipe	200 mm	1.25 to 10 mm	15 mm depth CP606 on top of the gap backed with min. 100 mm depth by 100 kg/m ³ mineral wool	120 mins
Copper pipe	200 mm	1.25 to 10 mm	15 mm depth CP601S on top of the gap backed with min. 100 mm depth by 100 kg/m ³ mineral wool	120 mins
Copper pipe	50 mm	1.25 to 10 mm	15 mm depth CP606 on top of the gap backed with min. 100 mm depth by 100 kg/m ³ mineral wool	240 mins
Steel pipe	200 mm	1.25 to 10 mm	15 mm depth CP606 on top of the gap backed with min. 100 mm depth by 100 kg/m ³ mineral wool	240 mins
Copper pipe	50 mm	1.25 to 10 mm	15 mm depth CP601S on top of the gap backed with min. 100 mm depth by 100 kg/m ³ mineral wool	240 mins
Steel pipe	200 mm	1.25 to 10 mm	15 mm depth CP601S on top of the gap backed with min. 100 mm depth by 100 kg/m ³ mineral wool	240 mins

In the above application, it is assumed that the supporting wall or floor construction shall carry at least equivalent fire resistance performance. The appraised condition only considers a single pipe penetrating a masonry aperture. The appraisal was performed against the integrity criteria as stated in BS 476: Part 20: 1987.

Discussion

The test evidence WARRES 101295/A described the test of the copper pipes penetrating through the apertures on both wall and floor supporting constructions. The pipes in the test were copper pipes with 42 mm pipe diameter and 1.25 mm wall thickness. The apertures on the supporting construction were 127 mm diameter, therefore created the annular gaps of 42 mm wide between the pipe and the supporting construction. The sealing systems that used were the Hilti “CP606” and “CP601S” backed with 100 kg/m³ mineral wool. The sealing systems achieved 240 minutes integrity performance, except that the “CP601S” sealing in wall mount situation achieved 157 minutes integrity performance only. The test was conducted generally in accordance with BS 476: Part 22: 1987 and adopting the testing procedure in BS EN 1366-3.

- (a) The test evidence described the pipe penetration system with copper pipe was used. It is proposed that the steel pipes shall be also acceptable since the steel has a significant higher melting point than copper and is a slightly less effective conductor of heat. It is therefore expected that the test result on copper pipes shall also applies to steel pipes as proposed. From reference, the melting point of copper is approximately 1,080 °C, which is equivalent to the furnace temperature at around 150 minutes following the standard heating curve as defined in BS 476: Part 20: 1987. The copper pipe is likely to melt beyond 150 minutes of the test, and at the heating time approach 120 minutes, the copper pipe may become softened due to heat. As such, it is suggested that the sizes of the diameter of the copper pipe in this appraisal shall be limited to 50 mm diameter which is slightly larger than the tested diameter of 42 mm.

While for the steel pipe, since the melting point of steel is significantly higher (approximately 1,300 °C), which is steel higher than the temperature at 240 minutes in accordance with the standard heating curve. In such case, it is considered that the steel pipe shall reinstate without significant deformation during the heating exposure of 240 minutes. It is suggested that the pipe diameter increased up to 200 mm is still acceptable.

In both copper pipe and steel pipe situation, the increase in pipe wall thickness increased the heat sink of the pipe and also the strength of the pipe. It is expected it shall aid the rigidity of the pipe and is positively appraised as well.

- (b) The proposed width of the annual gap of 42 mm wide is followed the tested situation in test evidence WARRES 101295/A. While the narrower annual gap represent a less onerous situation in terms of fire resistance performance. Provided that the same sealing method can be applied, the fire resistance performance for the sealing of narrow annular gap is positively appraised.
- (c) The proposed sealing method as stated in Table 4.2.1 and Table 4.2.2 are generally adopting the tested scenarios in the test evidence as mentioned in section 3, except that the pipe diameter is proposed to be increased up to 200 mm for the steel pipe application. Also, in the situation of copper pipe penetration though wall that requires 240 minutes integrity. Because the tested situation of 20 mm depth “CP601S” sealant backed with 60 mm depth x 100 kg/m³ mineral wool

through the 100 mm wall only achieved 157 minutes integrity, it is appraised that the depth of the mineral wool shall be increased to minimum 100 mm deep with the use of same density mineral wool, and therefore the minimum wall thickness for such case would be 150 mm. The sealant depth of 15 mm was tested and proven to be appropriate to provide 240 minutes integrity performance with the proper backing mineral wool.

- (d) In the test evidence R18G14-2A, the specimen no. '19' was a 139 mm diameter GI pipe penetrating through a 150 mm thick masonry wall with an aperture of 160 mm diameter. The annular gap in between the pipe and the aperture is filling with Hilti CF-F 750 filling foam with both ends sealed with 10 mm thick Hilti CP 606. Since only a single test point was recorded for the use of Hilti CF-F foam, the application is confined to the maximum pipe diameter same as that tested. And the smaller pipe is generally regarded as the less onerous situation and is therefore acceptable.

In summary, the proposed application conditions of the Hilti "CP606" or "CP601S" as given in Tables 4.2.1 to 4.2.2 are generally referenced to the tested condition, with some of them are appraised with a conservative approach.

5 CONCLUSION

The proposed use of Hilti “CP606” and “CP601S” firestop sealant for pipe penetration sealing systems in both floor mounted and wall mounted as discussed in Section 4 of this report, are capable to maintain the fire resistance performance of up to 240 minutes integrity performance with respect to BS 476: Part 20: 1987.

6 DECLARATION BY APPLICANT

We, Hilti (Hong Kong) Limited, confirm that the material, component or element of structure, which is the subject of the test report being reviewed, has not to our knowledge been subjected to another test to the standard against which the assessment is being made.

We agree to withdraw this assessment from circulation should the component or element of structure be the subject of another test to the standard against which the assessment is being made.

We are not aware of any information that could affect the conclusions of this assessment.

If we subsequently become aware of any such information we agree to ask the assessing authority to withdraw the assessment.

7 VALIDITY

This assessment is based on test data, experience and the information supplied. The assessment will be invalidated if the assessed construction is subsequently tested since actual test data is deemed to take precedence over an expressed opinion. Any changes in the specification of product will invalidate this assessment. This assessment relates only to the specimen assessed and does not by itself infer that the product is approved under any other endorsements, approval or certification scheme. Since the appraisal method is under development, the laboratory reserved the right to supersede this assessment in case the appraisal method had been changed.

This report only relates to the specimen(s) tested and may only be reproduced by the sponsor in full, without comment, abridgement and modifications.

8 SIGNATORIES

Assessment by:



Dr. SZE Lip-kit

Test Consultant

Research Engineering Development

Façade Consultants Limited

Reviewed by:



Ir Dr. YUEN Sai-wing, MHKIE (Fire)

Authorized Signature

Research Engineering Development

Façade Consultants Limited

APPENDIX A – SUMMARY OF APPLICATION OF SEALANTS IN DIFFERENT SCENARIOS

Drawing refers to Table 4.2.1 & 4.2.2 on metal pipe penetration application by using CP606 or CP601S

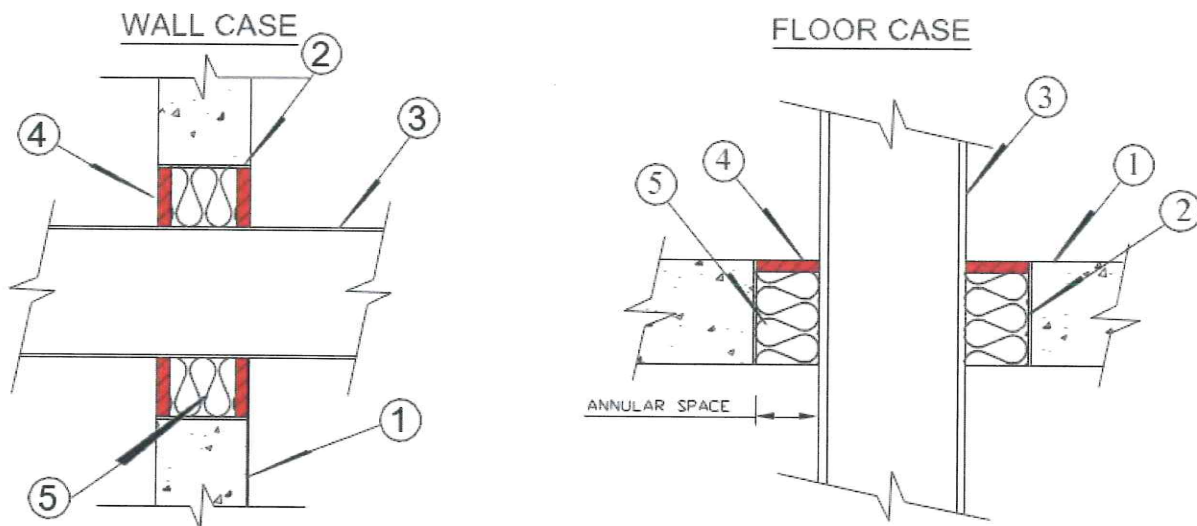

1. FLOOR ASSEMBLY: CONCRETE FLOOR
WALL ASSEMBLY: CONCRETE WALL OR FIRE-RATED BLOCK WALL
2. OPTIONAL: METAL SLEEVE
3. REPENETRATING ITEM: STEEL/CAST/D.I./COPPER PIPE
4. CP606 / CP601S
5. MINIMUM 100 KG/M³ DENSITY MINERAL WOOL AS BACKING MATERIAL

- End of Report -

Contents

1. Assumptions and Limitations
2. Background
3. Analysis
4. Assessment/Conclusion
5. Term of validity
6. Declaration by the applicant

Appendix – Drawing for the proposed pipe penetration sealing systems

Report Issue Record:	Version 1 – 2023-06-16
-----------------------------	------------------------

1. Assumptions and Limitations

It is assumed that the proposed assembly will be installed to a suitable fire resisting structure, such as a masonry/reinforced concrete structure or equivalent, which can provide the required supporting fire resistance period. The materials and constituents of the proposed assembly are in a similar manner and quality as tested or otherwise appraised by Forte Testing and Consultants Company Limited (FORTE). This assessment may only be reproduced in full by the applicant.

2. Background

This report is based on provided test evidence and we have been reviewed all of them against test procedures stated in BS 476: Part 20: 1987. The reports stated in this section have been reviewed. Those reports are record of the specific tests conducted according to a standard BS 476: Part 20: 1987 current at the time and, as such, there is no expiry date for the test reports. Our recommendation on reviewing the reports can be periodically to ensure the test standards are still updated and continue to satisfy the relevant regulatory requirements. As the time of the testing standard in according to BS 476: Part 20: 1987 has been no change, therefore the validity/status of the reports are not affected when the applicant and manufacturers for specific products confirmed the methods of construction and materials used as same as originally tested.

2.2 WARRES Test report number 69754/C

A fire resistance test in accordance with BS 476: Part 20: 1987 on 4 specimens, namely specimen 1 to 4, of liner gap sealing systems in wall or floor mounted with Hilti CP606 firestop acrylic sealant to reinstate the fire resistance performance. The test was performed by WARRES. Test sponsor was Hilti AG, who had permitted the applicant to use this data. Only the results from specimen 3 and 4 had been used for this assessment. The summary of the information and results of specimens were shown in following table:

Specimen	Gap width (mm)	CP606 Depth (mm)	Backing Material	Gap Faces	Integrity (mins)
3	30	15 mm (non-fire side only)	Rockfibre	Steel / Steel	240
4	30	15 mm (non-fire side only)	Rockfibre	Aerated autoclaved concrete/ Aerated autoclaved concrete	240

The test was terminated at 240 minutes. Full constructions details of the specimens and resulted were recorded in WARRES test report number 69754/C.

2.3 WARRES Test report number 143653

Fire resistance tests in accordance with BS 476: Part 20: 1987 on 8 specimens, namely specimen A to H, of liner penetration sealing systems in wall and floor mounted with Hilti CP 601S firestop silicon sealant to reinstate the fire resistance performance. Test sponsor was Hilti Entwicklung Befestigungstechnik GmbH, who had permitted the applicant to use this data. Only the results from specimen C and G had been used for this assessment. The summary of the information and results of specimens were shown in following table:

Specimen	Gap width (mm)	CP601S Depth (mm)	Backing Material	Gap Faces	Integrity (mins)
C	30	15 mm (non-fire side only)	35 mm Ø Backing Rod	Blockwork / Blockwork	240
G	30	15 mm (non-fire side only)	35 mm Ø Backing Rod	Aerated concrete/ Aerated concrete	240

The test was terminated at 240 minutes. Full constructions details of the specimens and resulted were recorded in WARRES test report number 101295/A.

3. Analysis

3.1 Penetration sealing systems

It is proposed that the penetration sealing systems with either Hilti CP606 or Hilti CP 601S, shown in table 1, have maximum 30 mm gap width in between maximum Ø600 mm steel pipe with from 1.25 mm to 10 mm pipe wall thickness. This assessment report will present the fire resistance of the penetration sealing systems, in terms of BS 476: Part 20: 1987, for a fire exposure of up to 240 minutes.

The proposed penetration sealing systems will be constructed generally in accordance with the specimens tested and described in test report 101295/A with the modification and variations of assessed in this section.

Product	Material of Service Pipe	Maximum Service Pipe Diameter	Pipe Wall Thickness	Seal Configuration
CP 606	Steel Pipe / Cast Iron Pipe/ Ductile Iron Pipe	600 mm	1.25 mm to 10 mm	Pipe Penetration at Wall: Min. 15 mm depth CP 606 (fire side) + Min. 60 mm depth Rockfibre with 100 kg/m ³ + Min. 15 mm CP 606 (non-fire side)
	Steel Pipe / Cast Iron Pipe/ Ductile Iron Pipe	600 mm	1.25 mm to 10 mm	Pipe Penetration at Floor: Min. 15 mm depth CP 606 (non-fire side) + Min. 100 mm depth Rockfibre with 100 kg/m ³
CP601S	Steel Pipe / Cast Iron Pipe/ Ductile Iron Pipe	600 mm	1.25 mm to 10 mm	Pipe Penetration at Wall: Min. 15 mm depth CP 601S (fire side) + Min. 60 mm depth Rockfibre with 100 kg/m ³ + Min. 15 mm CP 601S (non-fire side)
	Steel Pipe / Cast Iron Pipe/ Ductile Iron Pipe	600 mm	1.25 mm to 10 mm	Pipe Penetration at Floor: Min. 15 mm depth CP 601S (non-fire side) + Min. 100 mm depth Rockfibre with 100 kg/m ³

Table 1 - Penetration sealing systems with Hilti CP 606 /CP 601S

INTEGRITY - Penetration sealing systems with Hilti CP 606 or Hilti CP 601S in between pipe and wall under vertical orientation

a) Material of pipe and increase of the pipe thickness up to 10 mm

When there is a change on the pipe material, the main considerations are the structural adequacy and integrity of the systems. In report number 101295/A, Specimen A (20 mm CP 606 + 60 mm Rockfiber with 100 kg/m³ + 20 mm CP 606) and Specimen D (20 mm CP 601S + 60 mm Rockfiber with 100 kg/m³ + 20 mm CP 601S) with the 42 mm gap width have satisfied the integrity of 240 minutes and 157 minutes in accordance with BS 476: Part 20 respectively. This evidence is shown that the difference type of sealants used for the vertical penetration system with difference fire resistance period. Refer to the table of the observation during the test shown in report number 101295/A (page 22 of 22), the seal system of Specimen D ignited and flames continuously and the exposed length of 1.25 mm thick copper pipe of Specimen D fell away into the furnace at the heating period of 157 minutes. It is obviously to show that the copper pipe softening under the particular temperature will significantly degrade the strength, hardness and other mechanical properties of the pipe to damage penetration system. Refer to Specimen A, the penetration system with similar sealant can fulfil the integrity requirements when the integrity of the copper pipe maintain.

The approximate temperatures at which copper pipe and cast iron/steel pipe will start to soften are summarized as below: Copper pipe (annealed copper): 120-150 degrees °C; Cast iron pipe: 1000-1100 degrees °C; Steel pipe (carbon steel): 600-700 degrees °C. Copper will become soft and malleable at relatively low temperatures. Cast iron contains carbon and other alloying elements that make it extremely hard at room temperature. Very high temperatures are required to overcome these hardening effects and soften cast iron. As cast iron, steel is hardened by carbon and other alloying carbon and thus high heat is needed to soften it. The proposed cast iron or steel pipe will be with wall thickness of from 1.25 mm to 10 mm and it is reasonable believed that those pipes will be more robust that tested 1.25 mm copper pipe. Therefore, the proposed cast iron/steel/ductile iron pipe with specific penetration seal system as mention above table 1 would offer integrity protection to gap. Moreover, it is important that the cast iron/steel pipe shall be supported separately by with suitable supporting hangers are installed correctly.

b) Seal configuration and maximum service pipe diameter

In general, the longer gap length of the penetration seal system with bigger diameter of pipe is more onerous during a fire test when compares with the short gap length of the penetration seal system with smaller diameter of pipe.

Test results of report number 69754/C and 143653 are shown that Specimen 3 (15 mm CP606 + 70 mm Rockfiber with 140 kg/m³) and Specimen D (15 mm CP601S + 35 mm Ø PE Open Cell Foam Backing Rod) with the liner gap length not less than 900 mm have satisfied the integrity not less than 240 minutes. The specimen 3 demonstrates that the gap interface is steel and the penetration seal system and the Specimen D has been use the combustible backing rod to hold the sealant in the position. Those relative frail systems also have ability in retaining integrity for 240 minutes with no failure occurrence

The proposed circular penetration seal system can provide more comprehensive protection from direct flame/fire exposure since they fully surround the pipe at the penetration section. It will distribute stresses more evenly which prevents premature cracking or failure. Circular seals can achieve higher fire ratings and better contain pressure during the high temperature. Moreover, the circular penetration seal system accommodates potential expansion, contraction, vibration and high-pressure pulses in steel pipes more readily. They are less prone to damage from these types of movements.

As long as the quality of the materials for gap sealing systems are the same to that of the fire-tested types as shown in test evidences, it is believed that the gap sealing systems with CP606 and CP601S penetration seal system in between the cast iron/steel/ductile iron pipe and wall in either vertical orientation will not adversely affect achieved the fire performance as those are the non-combustible material. It is also importance that any brand of proposed rock wool must have the availability of the test data to show that it is a non-combustible material of the specific standard, such as BS 476: Part 4 or BS EN 13501-1.

INTEGRITY - Penetration sealing systems with Hilti CP 606 or Hilti CP 601S in between pipe and floor under horizontal orientation

c) Material of pipe and increase of the pipe thickness up to 10 mm

When there is a change on the pipe material, the main considerations are the structural adequacy and integrity of the systems. In report number 101295/A, Specimen F (20 mm CP606 + 100 mm Rockfibre with 100 kg/m³) and Specimen G (20 mm CP601S + 100 mm Rockfibre with 100 kg/m³) with the 42 mm gap width have satisfied the integrity of 240 minutes in accordance with BS 476: Part 20. This evidence is shown that the difference type of sealants used for the horizontal penetration system with no integrity failure occurrence. Refer to the table of the observation during the test shown in report number 101295/A (page 22 of 22), the seal system of Specimen D ignited and flames continuously and the exposed length of 1.25 mm thick copper pipe of Specimen D fell away into the furnace at the heating period of 157 minutes. It is obviously to show that the copper pipe softening under the particular temperature will significantly degrade the strength, hardness and other mechanical properties of the pipe to damage penetration system.

The approximate temperatures at which copper pipe and cast iron/steel pipe will start to soften are summarized as below: Copper pipe (annealed copper): 120-150 degrees °C; Cast iron pipe: 1000-1100 degrees °C; Steel pipe (carbon steel): 600-700 degrees °C. Copper will become soft and malleable at relatively low temperatures. Cast iron contains carbon and other alloying elements that make it extremely hard at room temperature. Very high temperatures are required to overcome these hardening effects and soften cast iron. As cast iron, steel is hardened by carbon and other alloying carbon and thus high heat is needed to soften it. The proposed cast iron or steel pipe will be with wall thickness of from 1.25 mm to 10 mm and it is reasonable believed that those pipes will be more robust than tested 1.25 mm copper pipe. Therefore, the proposed cast iron/steel pipe with specific penetration seal system as mentioned above table 1 would offer integrity protection to gap. Moreover, it is important that the cast iron/steel/ductile iron pipe shall be supported separately by with suitable supporting hangers are installed correctly.

d) Seal configuration and maximum service pipe diameter

In general, the longer gap length of the penetration seal system with bigger diameter of pipe is more onerous during a fire test when compares with the short gap length of the penetration seal system with smaller diameter of pipe.

Test results of report number 69754/C and 143653 are shown that Specimen 3, Specimen 4 (15 mm CP606 + 70 mm rock fibre with 140 kg/m³), Specimen D and Specimen G (15 mm CP601S + 35 mm Ø PE Open Cell Foam Backing Rod) with the linear gap length not less than 900 mm have satisfied the integrity not less than 240 minutes. The specimen 3 demonstrates that the gap interface is steel and the penetration seal system and the Specimen D has been used the combustible backing rod to hold the sealant in the position. Those relative frail systems also have ability in retaining integrity for 240 minutes with no failure occurrence.

The proposed circular penetration seal system can provide more comprehensive protection from direct flame/fire exposure since they fully surround the pipe at the penetration section. It will distribute stresses more evenly which prevents premature cracking or failure. Circular seals can achieve higher fire ratings and better contain pressure during the high temperature. Moreover, the circular penetration seal system accommodates potential expansion, contraction, vibration and high-pressure pulses in steel pipes more readily. They are less prone to damage from these types of movements.

As long as the quality of the materials for gap sealing systems are the same to that of the fire-tested types as shown in test evidences, it is believed that the gap sealing systems with CP606 and CP601S penetration seal system in between the cast iron/steel/ductile iron pipe and wall in either horizontal orientation will not adversely affect achieved the fire performance as those are the non-combustible material. It is also importance that any brand of proposed rock wool must have the availability of the test data to show that it is a non-combustible material of the specific standard, such as BS 476: Part 4 or BS EN 13501-1.

4. Assessment/Conclusion

It is concluded that the pipe penetration sealing systems between wall/floor and cast iron/steel/ductile iron pipe with the variations detailed in Section 3 of this report will to achieve a performance of 240 minutes integrity if test in according to BS 476: Part 20: 1987.

5. Term of validity

This assessment is issued on the basis of test data and information to hand at the time of issue, and is valid only if presented with proper test evidence(s) and all noted supporting data. If contradictory evidence becomes available to FORTE, the assessment will be unconditionally withdrawn and the applicant will be notified in writing. Similarly the assessment is invalidated if the assessed construction is subsequently tested since actual test data is deemed to take precedence over an expressed opinion. This assessment will expire on 16 June 2028, which time it is recommended that it will be submitted to FORTE for re-appraisal. This assessment is not valid unless it incorporates the declaration duly signed by the applicant.

For and on behalf of FORTE Testing and Consultants Company Limited:



CHENG San Mei, Sammi
Laboratory Manager



Ir Prof CHAN Yuk Kit, James, MH, JP, RPE (Fire)
Managing Director

6. Declaration by the applicant

- We the undersigned confirm that we have read and complied with the obligations placed on us by this guide on undertaking assessments.
- We confirm that the component or element of structure, which is the subject of this assessment, has not to our knowledge been subjected to a fire test to the standard against which this assessment is being made.
- We agree to withdraw this assessment from circulation should the component or element of structure be the subject of a fire test to the standard against which this assessment is being made.
- We are not aware of any information that could affect the conclusions of this assessment.
- If we subsequently become aware of any such information we agree to ask FORTE to withdraw the assessment.

Name: Dennis Yeung

Signed:  

For and on behalf of: Hiti (Hong Kong) Limited

Appendix A - Metal pipe penetration application by using CP 606 or CP 601S

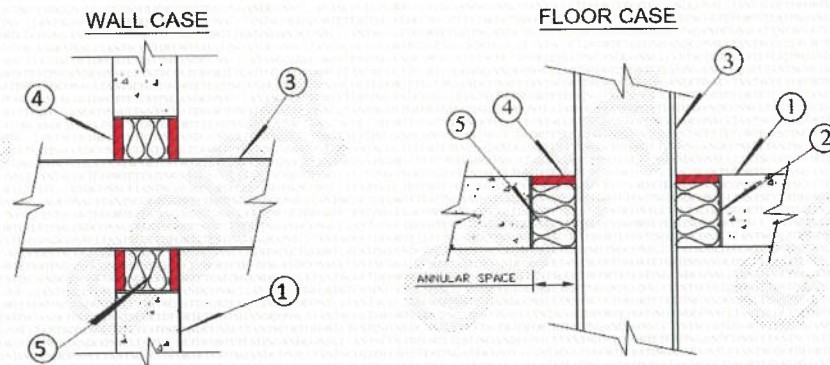

1. CONCRETE FLOOR OR WALL ASSEMBLY:
 - A. CONCRETE WALL OR FIRE-RATED BLOCKWALL
 - B. CONCRETE FLOOR
 2. OPTIONAL: METAL SLEEVE
 3. PENETRATING ITEM: STEEL / CAST / D.I. PIPE
 4. CP 606 / CP 601S
 5. FOR MINERAL WOOL AS BACKING MATERIAL, BY 100 KG/M³ AS MINIMUM DENSITY
-

ASSESSMENT REPORT

The use of Hilti 'CP606' fire rated sealant for the gap sealing between door frame and supporting construction

Report No.: R22D25-1A Issue 2

Issue Date: 6 August, 2024

Date of Review: 5 July, 2025

Report Sponsor

Hilti (Hong Kong) Limited

701-704 & 708B, Tower A Manulife Finance Centre,
223 Wai Yip Street, Kwun Tong, Kowloon, HK

This report only relates to the specimen(s) tested and may only be reproduced by the sponsor in full, without comment, abridgement and modifications.

CONTENT

Section	Description	Page
1	INTRODUCTION	3
2	ASSUMPTIONS	3
3	SUPPORTING DATA	4
4	PROPOSAL & DISCUSSION	10
5	CONCLUSION	13
6	DECLARATION BY APPLICANT	13
7	VALIDITY	13
8	SIGNATORIES	13

REVISION HISTORY

Issue date (DD/MM/YYYY)	Issue number	Remark
06/07/2022	0	Initial version
25/04/2024	1	Incorporate additional scope of gap width less than 5 mm.
06/08/2024	2	Correction of typographic error in table 4.1.1

**THE USE OF HILTI 'CP606' FIRE RATED SEALANT FOR THE GAP SEALING BETWEEN
DOOR FRAME AND SUPPORTING CONSTRUCTION**

1 INTRODUCTION

This assessment report presents an appraisal for the use of the Hilti 'CP606' fire rated sealant to seal the gaps in between the door frame and the supporting construction. The appraisal will be based on the test evidence as shown in section 3 of this report. This report is prepared for Hilti (Hong Kong) Limited of 701-704 & 708B, Tower A, Manulife Finance Centre, 223 Wai Yip Street, Kwun Tong, Kowloon, HK. The proposed gap sealing systems used for the doorsets are required to provide a fire resistance performance of up to 120 minutes integrity and insulation with respect to BS 476: Part 20/22: 1987.

2 ASSUMPTIONS

The proposed doorsets are assumed to be installed in a similar manner to that of the previously tested system by competent installers. It is assumed that the modified doorsets will be constructed in a similar manner from materials and components of the same manufacture and equivalent quality as tested with supporting test evidence or otherwise appraised by RED. Further assumptions related to the specific modifications will be stated in the report.

It is also assumed that the supporting structures to which the perimeter of the doorsets will be fixed are capable of supporting the proposed structure effectively.

Assuming that the issue of the original test report is valid, the current testing standard or testing experience has not been changed and the procedures adopted for the original report have been re-examined and reviewed that there have been no changes to the specification of the construction considered in the original report. If contradictory data or any related evidence becomes available to RED, the assessment will be unconditionally withdrawn and the sponsor will be notified. This report is based on the given information, in which is declared by report sponsor that no contradictory data has become available.

3 SUPPORTING DATA

3.1 Summary of Supporting Test Evidences

Report no.	Sections	Description
Primary Test Evidence		
R15A34-4A	4.1	Supporting test evidence for the use of the Hilt 'CP606' fire rated sealant for timber based doorset up to 240 minutes FRR.
Secondary Test Evidence		
WF150013B	4.1	The application of the Hilti 'CP606' sealant for linear gap sealing purpose in between the AAC and Hardwood facing
WARRES 69754/C	4.1	The application method of the Hilti 'CP606' sealant for linear gap sealing purpose in between the AAC facings
SP test report no. 97R1 3024C	4.1	Supporting test evidence Supporting test evidence for the use of the Hilti "CP606" sealant for the purpose of sealing wall mounted linear gap joint between wooden interface. The test was conducted in accordance with ISO 834.

3.2 Primary Test Evidence

3.2.1 RED Test Report No. R15A34-4A^

A fire resistance test in accordance with BS EN 1634-1: 2008 on a specimen of fully insulated single-acting, unequal double-leaf composite timber doorset was performed at the RED laboratory on 14 October 2015. The test sponsor was Faith Mark Consultants Limited, who had given permission to use this data.

As requested by the test sponsor, the specimen was mounted within concrete lined specimen holder by test sponsor such that the door leaves were swinging towards the heating conditions. The doorset was asymmetrical and only one side of the specimen was tested, in which the fire side was determined by the test sponsor.

The doorset was double leaves configuration and had overall dimensions of 2,012 mm wide by 2,407 mm high by 150 mm frame thickness. It was comprised of a door frame with unequal single-acting door leaves. The door leaves were constructed by nominal 50 mm thick ceramic fibre wool core sandwiched by nominal 12 mm thick 'Fire Star Board' calcium silicate boards with nominal 3 mm thick plywood facings fixed on both sides. Left door leaf was with sizes of 800 mm wide by 2,350 mm high by nominal 80 mm thick and right door leaf was with sizes of 1,100 mm wide by 2,350 mm high by nominal 80 mm thick. An unequal rebate with sizes of 12 mm wide by 20 mm thick rebate was incorporated in the meeting edge of door leaves. Left door leaf was hung to the door frame by 4 nos. of stainless steel spring hinges with sizes of 112 mm by 112 mm by 3 mm thick. Right door leaf was hung to the door frame by 4 nos. of stainless steel butt hinges with sizes of 112 mm by 112 mm by 3 mm thick. A nominal 71 mm thick glazed panel with aperture sizes of 358 mm wide by 1,050 mm high was incorporated in left door leaf. A nominal 71 mm thick glazed panel with aperture sizes of 500 mm wide by 500 mm high was incorporated in right door leaf. 1 no. of 'Lorient' smoke seal with sizes of 12 mm wide by 12 mm thick and 2 nos. of 'Vica' fire seals with sizes of 20 mm wide by 4 mm thick were installed at jambs and head of door frame. 2 nos. of 'Vica' fire seals with sizes of 10 mm wide by 4 mm thick and 1 no. of 'Vica' fire seal with sizes of 40 mm wide by 4 mm thick were installed at meeting edge of each door leaf. 1 no. of 'Vica' fire seal with sizes of 40 mm wide by 4 mm thick and 1 no. of 'Vica' fire and smoke seal with sizes of 20 mm wide by 4 mm thick were installed at top edge of each door leaf. 2 nos. of 'Vica' fire and smoke seals with sizes of 20 mm wide by 4 mm thick were installed at bottom edge of right door leaf. 1 no. of 'Vica' fire and smoke seal with sizes of 20 mm wide by 4 mm thick and a 'Vica' bottom drop seal were installed at bottom edge of left door leaf. The gaps between the door frame to concrete lining supporting construction were sealed with Hilti 'CP 606' fire rated sealant.

A 'GEZE TS4000' surface overhead door closer was installed at right door leaf. A handle was installed at the exposed side of right door leaf and both sides of left door leaf. A 'JBPRO' flush bolt was installed at top and bottom of left door leaf. A 'GEZE' lockset was installed at right door leaf and the doorset was unbolted, unlatched and unlocked during the test.

The specimen satisfied the performance requirements specified in BS EN 1634-1: 2008 for the following periods:

Integrity:	Cotton Pad	242 Minutes (No failure)
	Gap Gauge	242 Minutes (No failure)
	Sustained Flaming	242 Minutes (No failure)
Insulation (I₂ excluding glazed panels):		234 Minutes
Insulation (Left glazed panel):		228 Minutes
Insulation (Right glazed panel):		242 Minutes

The test was discontinued after a heating period of 242 minutes (See R15A34-4A for full details).

^Note: the test data is more than five years old; we have reviewed this data against the current test procedures as per BS EN 1634-1: 2008 and found it suitable for this assessment.

3.3 Secondary Test Evidence

3.3.1 WARRES Test Report No. 69754/C*

A fire resistance test on four specimens of proprietary gap sealing systems incorporated between various floor sections stated to be using the general principles of BS 476: Part 20: 1987 and in conjunction with additional guidelines from the draft document CENT/TC127 N579 was performed at the WARRES laboratory on 14th November 1996. The test sponsor was Hilt Ag, who had given permission to use this data.

The test was performed on four different specimens of gap sealing systems referenced 1 to 4 for the purposes of the test. Three specimens were incorporated between aerated concrete gap faces, the fourth between steel gap faces. The gap referenced 1 and 2 were of nominal width 20 mm, those referenced 3 and 4 were of nominal width 30 mm, all were of nominal length 950 mm. Each gap was sealed using Hilti CP606 in conjunction with a proprietary backing material.

The performance of each specimen assessed against the integrity and insulation (maximum temperature rise) criteria of BS 476: Part 20: 1987, the results were expressed as follow:

Specimen Ref:	Gap Width (mm)	Gap Faces	CP606 Depth	Backing Material	Integrity (Min)	Insulation (Min)
1	20	AAC/AAC	10	PE	240	130
2	20	AAC/AAC	15	CF 125-50	240	208
3	30	Steel/Steel	15	Rockfibre	240	36
4	30	AAC/AAC	15	Rockfibre	240	216

The test was discontinued after a period of 240 minutes (See WARRES no. 69754/C for full details).

**Note: the test data is more than five years old; we have reviewed this data against the current test procedures as per BS476: Part 22: 1987 and found it suitable for this assessment.*

3.3.2 WF Test Report No. 150013/B#

A fire resistance test on four specimens of proprietary gap sealing systems incorporated between various floor sections stated to be using the general principles of BS EN 1363-1: 1999 with additional guideline referenced prEN1366-4 was performed at the Warringtonfire laboratory on 10th November 2005. The test sponsor was Hilti (Great Britain) Ltd, who had given permission to use this data.

The test was performed on four different specimens of gap sealing systems referenced 'A', 'B', 'C' and 'D' for the purposes of the test. All the specimens are the Hilti 'CP606' sealant applied to linear gaps formed in between the AAC/Hardwood facings. The specimen referenced 'A' was the Hilti 'CP606' sealant applied to nominally 18 mm wide by 900 mm long gap up to 5 mm deep backed with Polyethylene backing rod on each side. The specimen referenced 'B' and 'C' were the Hilti 'CP606' sealant applied to nominally 30 mm wide by 900 mm long gap up to 10 mm deep on each side. In Specimen 'B', the sealant was backed with Polyethylene backing rod on each side and Specimen 'C' was the sealant backed with full depth of mineral fibre. The specimen referenced 'D' was the Hilti 'CP606' sealant applied to nominally 9 mm wide by 900 mm long gap up to 5 mm deep on each side backed with full depth of mineral fibre.

The performance of each specimen assessed against the integrity and insulation (mean and maximum temperature rise) criteria of BS EN 1363-1, the results were expressed as follow:

Specimen Ref:	Gap Width (mm)	Gap Faces	CP606 Depth	Backing Material	Integrity (Min)	Insulation (Min)
1	18	AAC/Hardwood	5	PE	92	90
2	30	AAC/Hardwood	10	PE	90	84
3	30	AAC/Hardwood	10	Mineral fibre	160	153
4	9	AAC/Hardwood	5	Mineral fibre	160	152

The test was discontinued after a period of 164 minutes (See WF report no. 150013/B for full details).

#Note: the test data is more than five years old; we have reviewed this data against the current test procedures as per EN 1363-1: 1999 and found it suitable for this assessment.

3.3.3 SP Test Report no. 97R1 3024C^

A fire resistance test in accordance with SIS 02 48 20, edition 2 to evaluate the fire resistance performance of the linear gap sealing systems was performed by the SP testing laboratory on 20th November, 1997. The report was prepared for Hilti Svenska AB, the Hilti Entwicklungsgesellschaft mbH had given permission to use this data.

The test described various cable services penetrations sealing, cable penetration sealing systems, pipe service penetrations and linear joint sealing systems. In this appraisal, only the linear joint sealing systems using the "CP606", reference "16" was considered.

Joint 16 was the linear gap created to simulate wood/wood interface at the joint. The gap width is 30 mm and applied with 15 mm deep Hilti "CP606" sealant on the unexposed side backed with rockfibre material. The specimens satisfied the performance requirements specified in the SIS 02 48 20, edition 2 for the following periods:

Joint '16'

Integrity: 123 Minutes (No failure)

Insulation: 123 Minutes

The test was discontinued after a heating period of 126 minutes (See SP report no. 97R1 3024C for full details).

^Note: the test standard SIS 02 48 20 edition 2, was a test standard with the heating and pressure conditions are identical to those specified in BS 476: Part 20: 1987. The test data is therefore considered as acceptable to be used as the secondary test evidence for the use of Hilti CP 606 sealant

4 PROPOSAL & DISCUSSION

4.1 The use of Hilti 'CP606' sealant for the purpose of doorsets perimeter gaps sealing

Proposal

It is proposed that Hilti 'CP 606' may be used for the purpose of perimeter gap sealing for fire resistance doorsets, provided that the doorsets were previously tested with respect to BS 476: Part 22: 1987 for the fire resistance period of up to 60 minutes or 120 minutes.

It is proposed that the Hilti 'CP606' may be used to replace the tested sealant based on the range of application as stated below.

Table 4.1.1: Proposed use of Hilti 'CP606' for different scenarios

Description	Backing material	Gap width (mm)	Depth of sealant (mm)	Integrity (min) [@]	Insulation (min) [@]
Between Timber Door frame/ timber sub-frame and Concrete/AAC supporting construction	Optional	≤ 5	5	120	0
	PE rod	≤ 10	5	120	0
		10 < gap width ≤ 18	5	90	90
		18 < gap width ≤ 30	10	90	60
	Mineral wool	≤ 30	10	120	120
Between timber door frame and timber sub-frame	PE rod	≤ 30	10	60	0
		≤ 10	5	90	0
	Mineral wool	≤ 30	10	90	90
			15	120	120
Between steel door frame and concrete/AAC supporting	Mineral wool	≤ 30	15	240	0

[@]Note: the integrity and insulation performance subjected to the original tested doorset had achieved the fire resistance performance no less than that shown in the table.

For the application of the Hilti "CP606" sealant backed with or without PE rod, the sealant together with the backing material shall be applied to both sides of the gap. The PE rod shall be friction fitted to the gap. In the application of the Hilti "CP606" with mineral wool backing, the backing materials shall be at least 100 kg/m³ to the full depth. The gap shall be covered by architrave on both sides, the architrave may be the same material as the

Discussion

The test evidence R15A34-4A reported a test of a double-leaf composite timber doorset assessed against the BS EN 1634-1: 2008. The doorset was composed of composite timber door frame and installed within a concrete lined aperture with sub-frame. The gap in between the door frame, sub-frame and the concrete supporting construction was filled with the Hilti 'CP606' sealant. The doorset had achieved the fire resistance performance of 242 minutes integrity and 234 minutes insulation.

The test evidence R15A34-4A proven the nominal use of the Hilti 'CP606' sealant will not deteriorate the fire resistance performance of the doorset for up to 240 minutes. However, this test evidence had not clearly shown the clearance gap between the door sub-frame and the concrete supporting construction, it is understood the clearance shall be nominally 10 mm. Since the BS EN 1634-1: 2008 is the latest fire resistance test standard applicable to fire doors. In reviewing the tests, we have considered the design and installation of the specimen, the surrounding construction, the initial furnace temperature, the pressure in the furnace, the changes in integrity and insulation criteria and the behaviour of the fire test, it is expected that if these fire tests had been conducted in accordance with BS 476: Part 22: 1987 very similar results would have been achieved.

Fire test to BS EN 1634-1: 2008 and BS 476: Part 22: 1987 have the same furnace temperature-time curve, i.e., the standard ISO temperature time curve represented by $T = 345 \log_{10}(8t + 1) + 20$, where T is the furnace temperature rise and t is the time of heating conditions. However, a more severe overpressure requirement of 5 Pa required by BS EN 1634-1: 2008 was used, which was normally deemed to be more onerous. The passing criteria for the standards of BS EN 1634-1: 2008 and BS 476: Part 22: 1987 are summarised as follows:

Integrity. Monitor the unexposed face of the specimen for evaluation of integrity. A failure of the test construction to maintain integrity occurs when collapse or sustained flaming on the unexposed face occurs or impermeability is exceeded.

Insulation. Failure occurs when (a) the mean unexposed face temperature increases by more than 140 °C above its initial value; or (b) the temperature recorded at any position on the unexposed face is in excess of 180 °C above its initial value; or (c) when integrity failure occurs.

Since the integrity and insulation criteria of BS EN 1634-1: 2008 and BS 476: Part 22: 1987 are basically the same, we can conservatively conclude that the insulated partition systems as tested and described in the test evidence will achieve similar results. Therefore, the use of the result from the BS EN 1634-1: 2008 for the assessment against BS 476: Part 22: 1987 is considered acceptable.

In the test evidence WF Test Report No. 150013/B, the test was performed on four specimens, referenced "A", "B", "C" and "D" using Hilti 'CP606' sealant applied to linear gaps formed in between the AAC/Hardwood facings. The specimen referenced 'A' was the Hilti 'CP606' sealant applied to nominally

18 mm wide by 900 mm long gap up to 5 mm deep backed with Polyethylene backing rod on each side. The specimen referenced 'B' and 'C' were the Hilti 'CP606' sealant applied to nominally 30 mm wide by 900 mm long gap up to 10 mm deep on each side. In Specimen 'B', the sealant was backed with Polyethylene backing rod on each side and Specimen 'C' was the sealant backed with full depth of mineral fibre. The specimen referenced 'D' was the Hilti 'CP606' sealant applied to nominally 9 mm wide by 900 mm long gap up to 5 mm deep on each side backed with full depth of mineral fibre. Based on the test evidence, specimen with narrower gap is representing a less onerous situation. It is as proposed in the table, the gap less than 5 mm with the application of 5 mm depth of sealant on both sides of the door frame is considered as acceptable for the application of integrity performance only.

In considering the situation between the timber door frame and timber sub-frame, the test evidence SP test report no. 97R1 3024C was referenced. In this test evidence, the specimen referenced Joint 16 were the wood/wood interface linear joint with the gap width of 30 mm. The sealant 'CP 606' was applied to the joint of 15 mm deep on the unexposed side and backed with rockwool, respectively. The joint achieved the fire resistance performance 120 minutes integrity and insulation performance during the test. The proposed design requires the sealant applied on both sides, this is a more conservative design in term of fire resistance and the fire form either side shall behave the same as well.

The application method of the sealant may be referenced to another test evidence of WARRES No. 69754/C, which the same sealant was used to fill up the gap of horizontal linear gap within a concrete-to-concrete facings and steel-to-steel facings. From this test, the linear gap of concrete-to-concrete facings with the application of the Hilti 'CP606' sealant up to nominal 10 to 15 mm depth for the gap width of 20 to 30 mm had achieved the fire resistance performance of 240 minutes integrity and at least 130 minutes insulation performance for the wall thickness of 150 mm. Although BS 476: Part 20 was used as the testing standard, the proposed application methods are also justified to the tested situation for sufficient performance margins and therefore it is considered acceptable.

The proposal is to assess the replacement of the sealant that used with a previously tested doorsets, since the Hilti 'CP606' was proven to use with a fire resistance doorset up to 242 minutes integrity and 234 minutes insulation. Also, the Hilti 'CP606' had been tested as the linear joints sealing between different substrates. The proposed use of the Hilti 'CP606' as stated in Table 4.1.1 are directly adopting the tested condition.

The proposal for use in previously tested doorset up to 120 minutes integrity with or without insulation in timber doorsets and up to 240 minutes integrity only for steel doorsets with respect to BS 476: Part 22: 1987 is considered acceptable.

5 CONCLUSION

The proposed use of Hilti 'CP606' in replacing the sealant that use for previously tested fire resistance doorset may provide a fire resistance performance of up to 120 minutes integrity with or without insulation in timber doorsets and up to 240 minutes integrity only in steel doorsets with respect to BS 476: Part 20/22: 1987.

6 DECLARATION BY APPLICANT

We, Hilti (Hong Kong) Limited, confirm that the material, component or element of structure, which is the subject of the test report being reviewed, has not to our knowledge been subjected to another test to the standard against which the assessment is being made.

We agree to withdraw this assessment from circulation should the component or element of structure be the subject of another test to the standard against which the assessment is being made.

We are not aware of any information that could affect the conclusions of this assessment.

If we subsequently become aware of any such information we agree to ask the assessing authority to withdraw the assessment.

7 VALIDITY

This assessment is based on test data, experience and the information supplied. The assessment will be invalidated if the assessed construction is subsequently tested since actual test data is deemed to take precedence over an expressed opinion. Any changes in the specification of product will invalidate this assessment. This assessment relates only to the specimen assessed and does not by itself infer that the product is approved under any other endorsements, approval or certification scheme. Since the appraisal method is under development, the laboratory reserved the right to supersede this assessment in case the appraisal method had been changed.

This report only relates to the specimen(s) tested and may only be reproduced by the sponsor in full, without comment, abridgement and modifications.

8 SIGNATORIES

Assessment by:

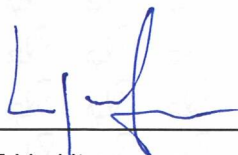

Dr. SZE Lip-kit

Test Consultant

Research Engineering Development

Façade Consultants Limited

Reviewed by:



Ir Dr. YUEN Sai-wing, MHKIE (Fire)

Authorized Signature

Research Engineering Development

Façade Consultants Limited

- End of Report -



88 Empire Drive • St. Paul, Minnesota • 55103
 (651) 642-1150 • fax (651) 642-1239

VOC Content Test Certificate

October 26, 2009

Supplier: Hilti Entwicklungsgesellschaft mbH
 BU Chemicals
 Hiltistrasse 6
 86916 Kaufering
 GERMANY

Sample Description: Hilti CP 606

Date tested: July 20, 2009

Test Method: SCAQMD method 304-91 Determination of Volatile Organic Compounds (VOC) in various materials as referenced by South Coast Air Quality Management District (SCAQMD) rule 1168. The values also comply with the requirements of EPA test method #24.

Test Data: Legend Project Number 0903311

Specification	Product
LEED 2009 (LEED 3.0) LEED 2.2 IEQ-4.1: Low-Emitting Materials – Architechtural Sealant	Hilti CP 606
Green Building Council of Australia Green Star Office Design 3.0, IEQ-13 Green Star Office Design 2.0, IEQ-13 Green Star Office Interiors 1.1, IEQ-11	
Architectural Sealant; VOC Limit: 250 g/L	Product contains: 75 g/L of VOC

William Welbes
 Vice President of Laboratory Operations

Allen Noreen, Ph.D.
 Technical Director

Hilti (Hong Kong) Ltd.
Unit 3 5/F Harbour Centre Tower 2
8 Hok Cheung Street Hung Hom
Kowloon

26 May 1994
Handwritten initials and a large cross mark.

Dear Sirs,

Fire Resisting Penetration Sealing System
As Supplied By Hilti (GB) Ltd.

Thank you for your letters dated 4.3.94 and 27.4.94 and the accompanying test/assessment reports on the above. You are asking for comments on the acceptability of the fire resisting product in the context of relevant provisions of the Buildings Ordinance, Chapter 123 of the Law of Hong Kong and its subsidiary legislation.

Under the Buildings Ordinance, "authorized persons" (i.e. architects, engineers or surveyors registered with the Building Authority) are required to supervise building works including the selection and installation of fire resisting products and to certify compliance with the Buildings Ordinance upon completion of works. Authorized persons are therefore responsible for ensuring the safety requirements inter alia of fire resisting products in the building projects which they have been appointed by the developer to coordinate and supervise.

In establishing the acceptability of fire resisting products, reference may be made to the performance standards laid down in Building (Construction) Regulation 90, the current Code of Practice for Fire Resisting Construction issued by the Building Authority and British Standard 476: Parts 20 to 24. Reliance may also be placed on the test/assessment report prepared by a recognized laboratory or an equivalent establishment.

The Buildings Department has a list of recognized laboratories. This is available for reference at our office :

Technical Administration (Building) Unit
Buildings Department
11/F Murray Building
Garden Road Hong Kong

Before fire resisting products are installed in a building project, the authorized person appointed for the project should be approached for advice and guidance.

Your test/assessment reports are returned herewith. In this respect, please note that paragraph 3 of my letter dated 25 January 1994 is no longer applicable. The delay in replying is regretted.

Yours faithfully,

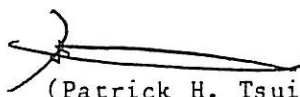
(Patrick H. Tsui)

Technical Secretary/Building
for Director of Buildings

消防處
防火組
香港九龍尖沙咀東部康莊道1號
消防總部大廈



FIRE SERVICES DEPARTMENT,
FIRE PROTECTION BUREAU,
FIRE SERVICES HEADQUARTERS BUILDING,
No. 1 Hong Chong Road,
Tsim Sha Tsui, East, Kowloon,
Hong Kong.

本處檔號 Our Ref.: FPB 207/0005
來函檔號 Your Ref.: L026/92HK
電訊掛號 Telex: 39607 HKFSD HX } (24 小時 Hours)
國文傳真 Fax: 852-3110066 }
852-3689744 }
電話 Tel. No.: 733 7596

29 April 1992

Hilti (Hong Kong) Ltd.,
Unit 3, 5/F, Harbour Centre,
Tower 2,
8 Hok Cheung Street,
Hung Hom, Kowloon.

Dear Sirs,

"HILTI" Fire Prevention System

I refer to your letter of 30.3.92 and the enclosures attached thereto.

Based on the information contained in your letter under reference and the given test report, I understand that the captioned product is a building material which should be approved by the Director of Buildings and Lands. As such, I am not in a position to process your application and you are advised to refer your enquiry to the Director of Buildings and Lands, whose address is listed hereunder :-

The Director of Buildings and Lands,
(Attn.: Technical Secretary/Building, B.O.O.)
Murray Building,
Garden Road,
Central,
Hong Kong.

Please feel free to contact us should you have any other question in this matter.

Yours faithfully,

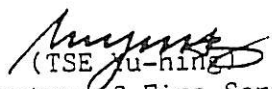
(TSE Yu-hing)
for Director of Fire Services

TYH/jt



ARCHITECTURAL SERVICES DEPARTMENT 建築署

QUEENSWAY GOVERNMENT OFFICES, 66 QUEENSWAY, HONG KONG. 香港金鐘道六十六號金鐘道政府合署
FAX 852-2869 0289

Our Ref : ASD 16/92101/AML/APP
Your Ref. : -----
Tel. No. : 2867 3631
Fax No. : 2877 0594

06 June 1997

Hilti (HK) Ltd
17/F, Tower 6, China HK City,
33 Canton Rd., TST

Dear Sirs,

Architectural Services Department
List of Acceptable Materials
Hilti Firestop Products
Ref. no. 0001P

I am pleased to inform you that approval has been given to include the above product/material in this Department's List of Acceptable Materials. Initially, this listing is for a probationary status and this will be reviewed after the submission of satisfactory performance reports on completion of projects undertaken by this Department where your product has been used.

The Architectural Services Department List of Acceptable Materials is a restricted internal document. This letter should not be used for commercial or marketing purposes and failure to comply with this may result in the removal of the product from the List.

Yours faithfully,

(W.M. TANG)
Technical Secretary/2
for Chief Architect/ Central Management Branch
Architectural Services Department

Attn. : To whom it may concern

Date : 26 September 2023
Ref. : 080/FP/DY/23

Subject : Country of Origin- Hilti CP 606 Flexible Firestop Sealant

Dear Sir / Madam,

Enclosed please find the information of Hilti CP 606 Flexible Firestop Sealant

Brand Name : Hilti

Model Name : Hilti CP 606 Flexible Firestop Sealant

Manufacturer : Hilti Corporation

Address of Manufacturer : FL-9494, Principality of Liechtenstein.

Manufacturer Contact Person : Dennis Yeung

Supplier : Hilti (Hong Kong) Ltd

Address of Supplier : 701-704, 7/F, Tower A, Manulife Financial Centre,
223 Wai Yip Street, Kwun Tong, Kowloon, Hong Kong

Supplier Contact Person : Dennis Yeung (+852 9723 4621)

Country of Origin : Germany

Should you have further questions, please do not hesitate to contact our Technical Representatives, Customer Service Hotline at 8228-8118, or email us at hksales@hilti.com.

Yours faithfully,



Dennis Yeung
Head of Product Leadership Strategy, F&P

Hilti (Hong Kong) Ltd.
701-704 | Tower A | Manulife Financial Centre
223 Wai Yip Street | Kwun Tong
Kowloon | Hong Kong
P +852-8228 8118 | F +852-2954 1751
www.hilti.com.hk



July 30, 2014

To Whom It May Concern:

Re: Hilti CP 606 Flexible Firestop – LEED Info.

- The Hilti CP 606 Flexible Firestop is manufactured in Germany.
- The package of Hilti CP 606 Flexible Firestop can be completely recycled.
- There is no recycled content in Hilti CP 606 Flexible Firestop and it cannot be recycled.
- The Hilti CP 606 Flexible Firestop does not share any rapidly renewable materials.
- The VOC content of Hilti CP 606 Flexible Firestop is 71 g/l.

If you would like to know more about Hilti solutions for LEED buildings or should you have any further question please feel free to contact me at my email or mobile number as shown below.

Sincerely,

Andrew Lau

Product Manager - Firestop

Hilti (Hong Kong) Limited

Email: andrew.lau@hilti.com

Mobile: (852) 9843-6291

Hilti (Hong Kong) Ltd.
701-704 | Tower A | Manulife Financial Centre
223 Wai Yip Street | Kwun Tong

Kowloon | Hong Kong

P +852-8228 8118 | **F** +852-2954 1751

www.hilti.com.hk

To whom it may concern

Date: 22nd April 2016

Dear Sir / Madam,

Subject: Hilti Firestop Products non-CFC and Ozone Confirmation

Referring to your enquiry about the captioned subject, please be advised that:

Hilti firestop products, CP606 Flexible Firestop Sealant is free of CFC, HCFC nor other ozone depletion elements.

CFC, HCFC and ozone depletion elements were not used during the product process neither.

Should you have further questions, please do not hesitate to contact our Technical Representatives or Customer Service Hotline at 8228-8118.

Yours sincerely,



Andrew Lau
Product Manger

CFS-S ACR; CP 606

Safety Data Sheet

according to the United Nations GHS (Rev. 4, 2011)

Issue date: 08/02/2021

Revision date: 08/02/2021

Supersedes: 02/10/2019

Version: 4.7

SECTION 1: Identification

1.1. GHS Product identifier

Product form	Mixture
Trade name	CFS-S ACR; CP 606
Type of product	Sealants
Product code	BU Fire Protection



1.2. Other means of identification

No additional information available

1.3. Recommended use of the chemical and restrictions on use

Use of the substance/mixture	Flexible firestop sealant
Recommended uses and restrictions	For professional users only
Recommended use	Adhesives, sealants

1.4. Supplier's details

Supplier

Hilti (Hong Kong) Ltd.
701-704, 7/F, Tower A, Manulife Financial Centre
223 Wai Yip Street, Kwun Tong
Kowloon - Hong Kong
T +852 27734 700
hksales@hilti.com

Department issuing data specification sheet

Hilti AG
Feldkircherstraße 100
9494 Schaan - Liechtenstein
T +423 234 2111
chemicals.hse@hilti.com

1.5. Emergency phone number

Emergency number	Schweizerisches Toxikologisches Informationszentrum – 24h Service +41 44 251 51 51 (international) +852 27734 700
------------------	---

SECTION 2: Hazard identification

2.1. Classification of the substance or mixture

Classification according to the United Nations GHS

Not classified

2.2. GHS Label elements, including precautionary statements

Labelling according to the United Nations GHS

2.3. Other hazards which do not result in classification

No additional information available

SECTION 3: Composition/information on ingredients

3.1. Substances

Not applicable

CFS-S ACR; CP 606

Safety Data Sheet

according to the United Nations GHS (Rev. 4, 2011)

3.2. Mixtures

This mixture does not contain any substances to be mentioned according to the applicable regulations

SECTION 4: First-aid measures

4.1. Description of necessary first-aid measures

First-aid measures general	Never give anything by mouth to an unconscious person. If you feel unwell, seek medical advice (show the label where possible).
First-aid measures after inhalation	Get medical advice/attention if you feel unwell. Allow affected person to breathe fresh air. Allow the victim to rest.
First-aid measures after skin contact	Wash skin with plenty of water. If skin irritation occurs: Get medical advice/attention. Remove affected clothing and wash all exposed skin area with mild soap and water, followed by warm water rinse.
First-aid measures after eye contact	Rinse cautiously with water for several minutes. Remove contact lenses, if present and easy to do. Continue rinsing. If eye irritation persists: Get medical advice/attention. Rinse immediately with plenty of water. Obtain medical attention if pain, blinking or redness persists.
First-aid measures after ingestion	Get medical advice/attention if you feel unwell. Rinse mouth. Do NOT induce vomiting. Obtain emergency medical attention.

4.2. Most important symptoms/effects, acute and delayed

Symptoms/effects	Not expected to present a significant hazard under anticipated conditions of normal use.
Potential adverse human health effects and symptoms	Based on available data, the classification criteria are not met.

4.3. Indication of immediate medical attention and special treatment needed, if necessary

No additional information available

SECTION 5: Fire-fighting measures

5.1. Suitable extinguishing media

Suitable extinguishing media	Water spray. Dry powder. Foam. Carbon dioxide. Sand.
Unsuitable extinguishing media	Do not use a heavy water stream.

5.2. Specific hazards arising from the chemical

Hazardous decomposition products in case of fire	Carbon dioxide. Carbon monoxide.
--	----------------------------------

5.3. Special protective actions for fire-fighters

Firefighting instructions	Use water spray or fog for cooling exposed containers. Exercise caution when fighting any chemical fire. Prevent fire fighting water from entering the environment.
Protection during firefighting	Self-contained breathing apparatus. Complete protective clothing. Do not enter fire area without proper protective equipment, including respiratory protection.

SECTION 6: Accidental release measures

6.1. Personal precautions, protective equipment and emergency procedures

6.1.1. For non-emergency personnel

Emergency procedures	Evacuate unnecessary personnel.
----------------------	---------------------------------

6.1.2. For emergency responders

Protective equipment	For further information refer to section 8: "Exposure controls/personal protection". Equip cleanup crew with proper protection.
Emergency procedures	Ventilate area.

CFS-S ACR; CP 606

Safety Data Sheet

according to the United Nations GHS (Rev. 4, 2011)

SECTION 9: Physical and chemical properties

9.1. Basic physical and chemical properties

Physical state	Solid
Appearance	Pasty
Molecular mass	Not determined
Colour	red. white. Grey.
Odour	characteristic.
Odour threshold	Not determined
Melting point	Not applicable
Freezing point	Not available
Boiling point	Not available
Flammability (solid, gas)	Not applicable, Non flammable.
Explosive limits	Not applicable
Lower explosive limit (LEL)	Not applicable
Upper explosive limit (UEL)	Not applicable
Flash point	Not applicable
Auto-ignition temperature	Not applicable
Decomposition temperature	Not available
pH	≈ 9 Not applicable
pH solution	Not available
Viscosity, kinematic (calculated value) (40 °C)	Not applicable
Partition coefficient n-octanol/water (Log Kow)	Not available
Vapour pressure	Not available
Vapour pressure at 50 °C	Not available
Density	1.6 g/cm ³
Relative density	Not available
Relative vapour density at 20 °C	Not applicable
Solubility	Not available
Particle size	Not available
Particle size distribution	Not available
Particle shape	Not available
Particle aspect ratio	Not available
Particle specific surface area	Not available

9.2. Data relevant with regard to physical hazard classes (supplemental)

No additional information available

SECTION 10: Stability and reactivity

10.1. Reactivity

The product is non-reactive under normal conditions of use, storage and transport.

10.2. Chemical stability

Stable under normal conditions. Not established.

10.3. Possibility of hazardous reactions

No dangerous reactions known under normal conditions of use. Not established.



CFS-S ACR; CP 606

Safety Data Sheet

according to the United Nations GHS (Rev. 4, 2011)

10.4. Conditions to avoid

None under recommended storage and handling conditions (see section 7). Direct sunlight. Extremely high or low temperatures.

10.5. Incompatible materials

Strong acids. Strong bases.

10.6. Hazardous decomposition products

Under normal conditions of storage and use, hazardous decomposition products should not be produced. fume. Carbon monoxide. Carbon dioxide.

SECTION 11: Toxicological information

11.1. Information on toxicological effects

Acute toxicity (oral)	Not classified
Acute toxicity (dermal)	Not classified
Acute toxicity (inhalation)	Not classified
Skin corrosion/irritation	Not classified
Serious eye damage/irritation	pH: ≈ 9 Not applicable
Respiratory or skin sensitisation	Not classified
Germ cell mutagenicity	Not classified
Carcinogenicity	Not classified
Reproductive toxicity	Not classified
STOT-single exposure	Not classified
STOT-repeated exposure	Not classified
Aspiration hazard	Not classified
Potential adverse human health effects and symptoms	Based on available data, the classification criteria are not met.

SECTION 12: Ecological information

12.1. Toxicity

Ecology - general	The product is not considered harmful to aquatic organisms nor to cause long-term adverse effects in the environment.
Hazardous to the aquatic environment, short-term (acute)	Not classified
Hazardous to the aquatic environment, long-term (chronic)	Not classified

12.2. Persistence and degradability

CFS-S ACR; CP 606	
Persistence and degradability	Not established.



CFS-S ACR; CP 606

Safety Data Sheet

according to the United Nations GHS (Rev. 4, 2011)

12.3. Bioaccumulative potential

CFS-S ACR; CP 606	
Bioaccumulative potential	Not established.

12.4. Mobility in soil

CFS-S ACR; CP 606	
Mobility in soil	No additional information available

12.5. Other adverse effects

Ozone	Not classified
Other adverse effects	No additional information available
Other information	Avoid release to the environment.

SECTION 13: Disposal considerations

13.1. Disposal methods

Waste treatment methods	Dispose in a safe manner in accordance with local/national regulations.
Product/Packaging disposal recommendations	Recycle the material as far as possible.
Additional information	European waste catalogue: 08 04 10 waste adhesives and sealants other than those mentioned in 08 04 09.

SECTION 14: Transport information

In accordance with ADR / RID / IMDG / IATA / ADN

ADR	IMDG	IATA	RID
14.1. UN number			
Not regulated	Not regulated	Not regulated	Not regulated
14.2. UN proper shipping name			
Not regulated	Not regulated	Not regulated	Not regulated
14.3. Transport hazard class(es)			
Not regulated	Not regulated	Not regulated	Not regulated
14.4. Packing group			
Not regulated	Not regulated	Not regulated	Not regulated
14.5. Environmental hazards			
Not regulated	Not regulated	Not regulated	Not regulated
No supplementary information available			

14.6. Special precautions for user

Overland transport

Not regulated

Transport by sea

Not regulated



CFS-S ACR; CP 606

Safety Data Sheet

according to the United Nations GHS (Rev. 4, 2011)

Air transport

Not regulated

Rail transport

Not regulated

14.7. Transport in bulk according to Annex II of Marpol and the IBC Code

Not applicable

SECTION 15: Regulatory information

15.1. Safety, health and environmental regulations specific for the product in question

No additional information available

SECTION 16: Other information

SDS Major/Minor	None
Issue date	08/02/2021
Revision date	08/02/2021
Supersedes	02/10/2019
Other information	None.

SDS_UN_Hilti

This information is based on our current knowledge and is intended to describe the product for the purposes of health, safety and environmental requirements only. It should not therefore be construed as guaranteeing any specific property of the product.



Hilti CP 606 Firestop Acrylic Sealant Job Reference

Year	Project Name	Customer Name	Project type
2020	Refurbishment - Residential - 380 Hiram's Highway, Sai Kung	KIN HING DOOR ENGINEERING LIMITED	Residential
2020	WANG WO TSAI ST, TWTL 126, 137, 160 & 363	BILLION BUILDING MATERIALS LIMITED	Residential
2020	TAI PO LAI CHI SHAN (221)	LAHINE ENGINEERING LIMITED	Residential
2020	NW KLN RECLAM 6 & FAT TSEUNG ST W	KWONG YIN WING KOO TIMBER CO LTD	Residential
2020	TKO LOHAS PARK PH9 (SITE J)	CHEUNG WAH BUILDING MATERIAL LTD	Residential
2020	TIN SHUI WAI AREA 112 LOT 33	WING FAT PLUMBING LIMITED	Residential
2020	TKO LOHAS PARK PH8 (SITE H)	YUN KEE SHUI TUNG WOODEN WORK	Residential
2020	KWUNTONG YUE MAN SQUARE DEVELOPMENT	EASY SMART ENGINEERING LIMITED	Residential
2020	TUEN MUN AREA 56 (500),KWUN CHUI RD	LEUNG'S WOODEN CO.	Residential
2020	7 MUK TAI ST, KAI TAK 1K3 (6565)	EVER GAIN AIR CONDITION ENGINEERING	Residential
2021	Refurbishment - Residential - 380 Hiram's Highway, Sai Kung	KIN HING DOOR ENGINEERING LIMITED	Residential
2021	AREA 54 TUNG CHUNG HOUSING	KWONG YIN WING KOO TIMBER CO LTD	Residential
2021	KAI TAK SPORTS PARK	SHUN HING WOOD WORKING CO LTD	Sport & Recreation
2021	KAI TAK SPORTS PARK	WELLYSON CONSTRUCTION COMPANY	Sport & Recreation
2021	TAIKOO PLACE PH 2B	LEE SHING MASONRY ENGINEERING	Office
2021	HANG TAI RD, MA ON SHAN AREA 86B PH 1&2 - HOUSING	KWONG YIN WING KOO TIMBER CO LTD	Residential
2021	Refurbishment - Residential - Various District	SHUNING BUILDING MATERIALS	Residential
2021	TAI WAI STATION NW RES	HOI SING DECORATION	Residential
2021	1-11 AU PUI WAN ST, FO TAN	LAHINE ENGINEERING LIMITED	Residential
2021	NW KLN RECLAM 6 & FAT TSEUNG ST W		Residential
2021	HKIA SKYCITY COMPLEX BLDG A2&A3	SAN WO COMPANY	Retail
2022	HKIA 3508 TERMINAL 2	EASY SMART ENGINEERING LIMITED	Transport
2022	KAI TAK SPORTS PARK	WELLYSON CONSTRUCTION COMPANY	Sport & Recreation
2022	ORGANIC RESOURCES RECOVERY CENTRE PH2 (WASTE TREA	KWONG YIN WING KOO TIMBER CO LTD	Utilities
2022	New - Residential - Lots No. 2281 S.A, 2282 RP, 2283 RP, 296	SUNNY FIRE BUILDING MATERIALS LTD	Residential
2022	POLICE SCHOOL RD HKU DORM (459)	PAUL Y. CONSTRUCTION CO LTD	Residential
2022	KWONG WAH HOSPITAL PH2	KWAN TAI ENGINEERING CO. LIMITED	Health
2022	HING WAH ST WEST LOT 6550 HOTEL	LAHINE ENGINEERING LIMITED	Hospitality
2022	HKIA SKYCITY COMPLEX BLDG A2&A3	SHEREX ENGINEERING LIMITED	Retail
2022	SIU HONG, AREA 54 DD 132 TMTL 483	RIDGID PLUMBING LIMITED	Residential
2022	KAI TAK AREA 4B, SITE 3, NKIL 6574	CHIT TAT ELECTRICAL ENGINEERING LTD	Residential
2023	KAI TAK SPORTS PARK	A & R ENGINEERING COMPANY LIMITED	Sport & Recreation
2023	HKIA 3508 TERMINAL 2	GAMMON ENGINEERING & CONSTRUCTION	Transport
2023	ASIAWORLD-EXPO PH 2	PAPEO CONSULTING GROUP LIMITED	Community & Cultural
2023	WANG WO TSAI ST, TWTL 126, 137, 160 & 363	BILLION BUILDING MATERIALS LIMITED	Residential
2023	KAI TAK AREA 4A, SITE 2, NKIL 6554	CHIT TAT ELECTRICAL ENGINEERING LTD	Residential
2023	KWAI CHUNG HOSPITAL PH2 & 3	ANTOP ENGINEERING COMPANY LIMITED	Health
2023	UNITED CHRISTIAN HOSPITAL	HIN TAT ENGINEERING LIMITED	Health
2023	KAI TAK AREA 4C, SITE 2, NKIL 6552	CHIT TAT ELECTRICAL ENGINEERING LTD	Residential
2023	IMMIGRATION HEADQUARTERS, TKO	LAHINE ENGINEERING LIMITED	Office
2023	SIU HONG, AREA 54 DD 132 TMTL 483	SHUN TUNG ENGINEERING CO LTD	Residential