

**X-BC rebar basket clip**

**Product Data**

X-BC C\_\_ P8

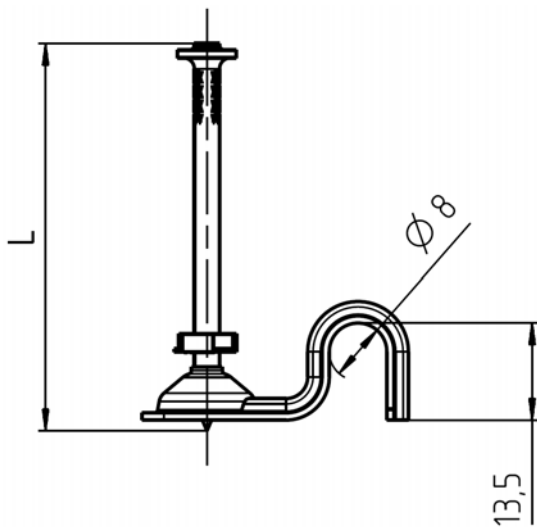

Fastening tool **DX 460-F8**



Cartridges:  
**6,8/11M,  
Red or Black**

Piston: X-460-P8  
Fastener Guide: X-460-F8

Specification

Cramp: carbon steel according to ASTM A109/A109M  
thickness: 1.0 mm  
surface oiled

Nail: carbon steel shank: HRC 53  
zinc coated: 5-13 µm  
diameter: 3,5 mm

**Application**

Intended use:

The rebar basket clip is used by the transportation industry in the building of concrete highways and roads. The clip must hold the rebar basket in place when concrete is poured. Application is the attachment of a rebar basket device to a road bed of either cementations compact gravel or asphalt.



## Standard basket clips

Designation	Article No	Box Contents	Tool
X-BC C47 P8	408257	1000	DX 460-F8
X-BC C62 P8	408255	1000	DX 460-F8

## Fastening Quality Assurance

### Fastening inspection

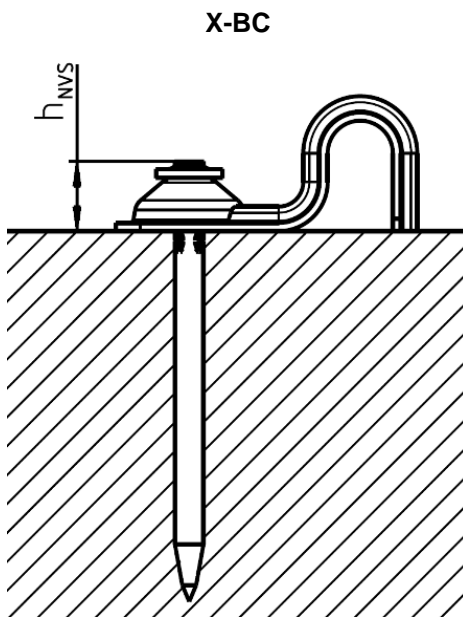

$h_{NVS} = 5 \text{ to } 9 \text{ mm}$



The photograph gives a visual impression of a correctly driven pin.

$h_{NVS}$  ... Nail head standoff = Distance from top of the driven pin to the top surface of the base material.